

# FC INSTRUCTION

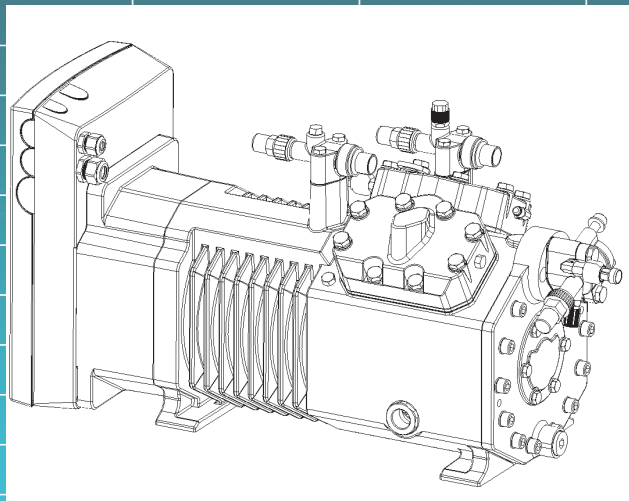

**Video instruction:**  
Replacement of FC

# FC INSTRUCTION



## Dismount the FC carefully

- Before replacement of FC, check FC according to service bulletin SB 00052.
- Ensure unit is disconnected from the main power.
- Only remove the 4 marked screws.

**Pic 1.** Please leave the black safety cover on during replacement.

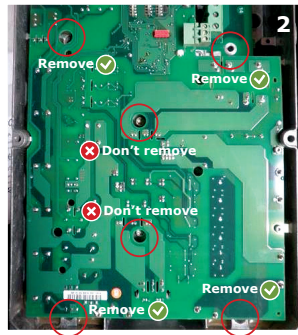

**Pic 2.** If possible leave the black safety cover on. The two screws at center should never be removed.

# FC INSTRUCTION



## Dismount the FC carefully

- Remove the FC by hand. In some cases it may be necessary to use a small press or scissor jack as shown



Apply penetration spray or liquid to assist loosening the studs when corrosion is present

STAR\*COOL

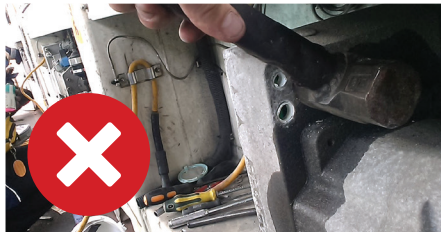

Never use a hammer on the FC

# FC INSTRUCTION



## Clean surfaces

- Clean the two surfaces on FC and compressor with abrasion paper and a scraper tool. Protect the FC PCB during this operation to prevent oxide dust entering

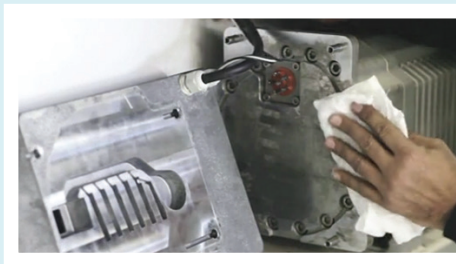

# FC INSTRUCTION



## Replace round studs

- The FC must never be installed with round studs. The 4 round studs have to be replaced with 4 square studs.

Apply Anti-Seize on areas marked with red.

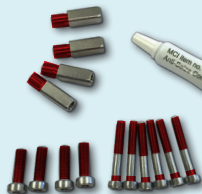

FC mounting kit:  
Item no. 818232B

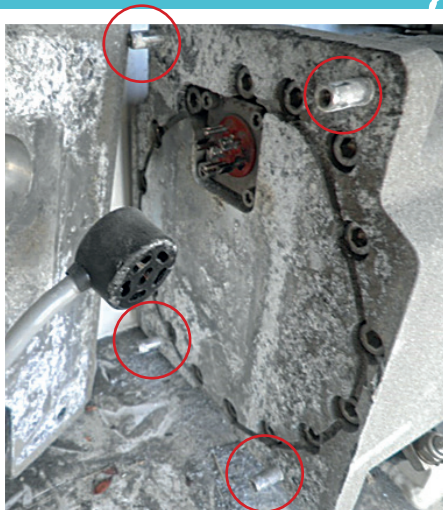

# FC INSTRUCTION



## Apply Thermo paste

- Apply a thin layer of thermal paste at the heat sink section.
- On a compressor without the gasket groove, apply an extra strip of thermal paste at the top of the FC as shown



Heat conducting paste HTPC 6g: Item no. 819904A

# FC INSTRUCTION



## Eliminate gaps

- No gaps are allowed between FC and the compressor.

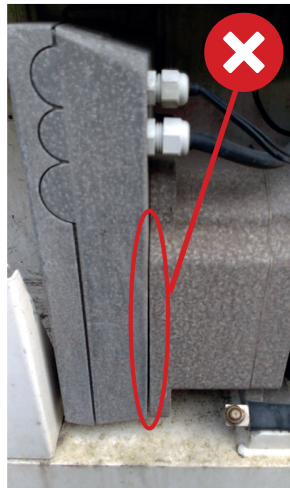
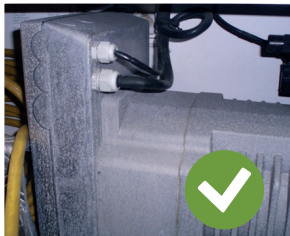

# FC INSTRUCTION



## Check cable gland

- Ensure the FC cover is properly installed and gasket is present

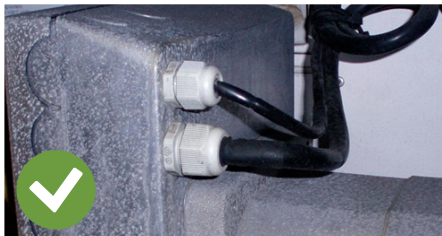
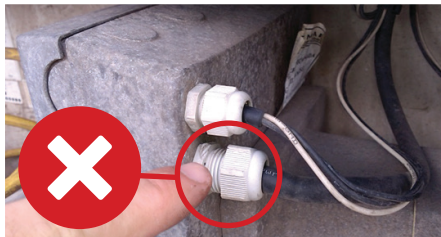



# FC INSTRUCTION



## Safety cover

- Safety cover for the FC must always follow the original FC and may not be removed.
- Serial numbers start with 176L8007 (those shall not be registered) thereafter 6 numbers, followed by letter G or A, finally 3 numbers. (eg. 934015G148, 673700A360)





## FC Cover

- FC cover must be free of damages. If any damages replace the cover. Item no. 814653C

If no spare is available (eg. from an old FC) seal up the hole instead of leaving it open.

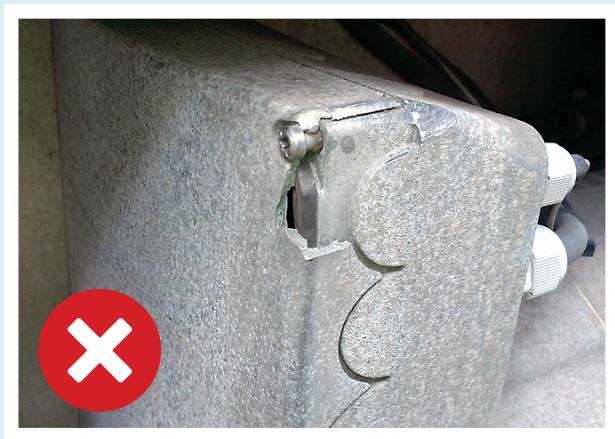

# FC INSTRUCTION



## FC bypass

- If the FC has been bypassed for emergency operation, place the defective FC securely in the cable tray with safety cover, lid and cable entries sealed against water





## Contacts

### Internet

[www.mcicontainers.com](http://www.mcicontainers.com)

### Spare parts / orders

[sales@starcool.com](mailto:sales@starcool.com)

### Service

[service@starcool.com](mailto:service@starcool.com)

### Logistic

[logistics@starcool.com](mailto:logistics@starcool.com)

### Technical Hot line 24/7

+45 73 64 35 00

### Skype

starcoolservice



### Alarm lists

<http://alarm.starcool.com>