



**TRANSICOLD**

# **Container Refrigeration Unit**

**Models**

**69NT20-274**

**69NT40-441**

**69NT40-444**

**69NT40-454**

**SERVICE  
PARTS LIST**



**TRANSICOLD**

# SERVICE PARTS LIST CONTAINER REFRIGERATION UNIT MODELS 69NT20-274 69NT40-441,-444 & -454

## CONTENTS

Introduction .....	i
Ordering Instructions .....	i
Letter Designations .....	i
Model Chart .....	ii
1. Quick List – Clamps, Filter-Drier, Fuse, Ty-Raps, and Wire Terminals ...	1
2. Tools .....	1
3. Refrigeration Unit Assembly .....	2
3.1 Refrigeration Unit – Front .....	2
3.2 Control Box Door .....	5
3.3 Control Box Door – <b>69NT40-444-15</b> .....	6
3.4 Control Box .....	7
3.5 Control Box – High Voltage Shield Removed .....	8
3.6 Control Box – Microprocessor Controller Box .....	11
3.7 Control Box – Microprocessor Controller Box – Cover Removed .	12
3.8 Condenser Fan Motor and Coil Section .....	14
3.9 Water-Cooled Condenser/Receiver and Tubing Section .....	16
3.10 Evaporator Fan Motor and Access Panel Section .....	18
3.11 Evaporator Coil Section – Rear Panels Removed .....	20
3.12 Evaporator Coil Section – Rear Panels Attached .....	22
3.13 Recording Thermometer (Partlow) .....	25
3.14 Recording Thermometer (Saginomiya) .....	26
3.15 Thermostatic Expansion Valve – Alco .....	28
3.16 Suction Solenoid Valve (69NT40 Only) .....	28
3.17 Modulating Solenoid Valve .....	29
3.18 Compressor Mounting And Gauges .....	30
3.19 Makeup Air Cover Option .....	31
3.20 Voltage Options .....	32
3.21 Labels and Decals .....	34
4. Accessories .....	36
4.1 Interrogator and Accessories .....	36
4.2 Battery and Charger Module .....	38
4.3 USDA “C” Size Battery Box .....	39
5. Compressor – Motor Assembly .....	41
5.1 Service Replacement Compressor .....	41
5.2 Terminal Mounting and Junction Box Group .....	41
5.3 Service Valve Group .....	41
5.4 Compressor – Motor Body Group .....	41
5.5 Pump End Group .....	42
5.6 Crankshaft, Rod and Piston Group .....	42
5.7 Valve Plate Group .....	43
5.8 Gasket Set .....	44
6. Controller and Recorder Sensors .....	45



## INTRODUCTION

This parts list identifies service replacement parts for the Carrier Transicold container Models listed in the Model Chart on page ii.

## ORDERING INSTRUCTIONS

All orders and inquiries for parts must include: Model, Unit Serial Number, part no., description of part as shown on list and quantity required. Address all correspondence for parts to the following address:

CARRIER TRANSICOLD DIVISION  
Replacement Components Group, TR-20  
P.O. Box 4805, Syracuse, New York 13221

## LETTER DESIGNATIONS

The following letter designations are used to classify parts throughout this list:

- A/R *As Required.*
- NLO *No Longer Offered.*
- NS *Not Shown in the illustration.*
- NSA *Non-Stock Assembly* – order components listed under the assembly.
- NSI *Non-Stock Item* – may be available on special order.
- NSS *Not Sold Separately* – order next higher assembly or kit.
- P-- *Suffix P--* – added to part number means part is available in packaged quantity only.  
Example: P/N34-00373-01P10 is a package of 10 P/N 34-00373-01.  
Use part number and P-- suffix when ordering.
- PL *Purchase Locally.*
- SST *Stainless Steel* – 300 Series unless otherwise specified.
- SV *Suffix SV* – added to part number designates service replacement part.

Model Chart

MODELS	Hinged Rear Panels	Two Speed Evaporator Fan Motors	Water-Cooled Condenser	Receiver	Power Transformer	Dual Voltage Compressor	Humidistat	Heat Exchanger
69NT20-274	-	X	A	-	-	-	X	-
69NT20-274-1	X	X	-	-	X	-	B	-
69NT40-444	-	X	A	-	-	-	X	-
69NT40-444-1	-	-	A	-	-	X	B	-
69NT40-444-2	-	X	A	-	-	-	X	-
69NT40-444-3	-	X	-	X	X	-	B	-
69NT40-444-4	X	-	-	X	-	X	B	-
69NT40-444-6	X	-	-	X	-	X	B	-
69NT40-454	-	X	X	-	-	-	B	-
<b>UNITS THAT HAVE PROVISIONS TO CONVERT TO R-22</b>								
69NT20-274-2	-	X	-	-	-	-	X	-
69NT20-274-3	-	X	-	X	-	-	X	C
69NT40-441-21	-	-	-	X	-	X	B	C
69NT40-441-22	-	-	-	X	-	X	B	C
69NT40-441-23	-	-	-	X	-	X	B	C
69NT40-441-24	-	X	-	X	-	-	X	C
69NT40-441-25	-	-	A	-	-	X	B	-
69NT40-444-7	-	X	-	X	X	-	B	-
69NT40-444-8	-	X	-	X	X	-	B	-
69NT40-444-9	-	X	-	X	-	-	X	-
69NT40-444-10	-	-	A	-	-	X	B	-
69NT40-444-11	-	X	-	X	-	-	X	-
69NT40-444-12	-	X	-	X	-	-	X	-
69NT40-444-13	-	X	-	X	-	-	X	-
69NT40-444-14	-	X	-	-	-	-	X	-
69NT40-444-15	X	X	-	X	X	-	B	-
69NT40-444-16	-	X	-	X	-	-	X	-
69NT40-444-17	-	X	-	X	X	-	B	-
69NT40-444-18	-	X	-	X	-	-	X	C
69NT40-444-19	-	X	-	X	-	-	X	C
69NT40-444-20	-	-	A	-	-	X	B	-
69NT40-444-21	-	-	A	-	-	X	B	-
69NT40-444-22	-	-	-	X	-	X	B	-
69NT40-444-23	-	-	-	X	-	X	B	C
69NT40-454-1	-	-	X	-	-	-	B	-
69NT40-454-2	-	X	X	-	-	-	B	-
69NT40-454-3	-	X	X	-	-	-	B	-

- A – Provision for water-cooled condenser. If water-cooled condenser is added, refrigerant charge will change.
- B – The microprocessor (Rev 104 or greater software) includes code 32 for dehumidification, even though the units do not have a humidistat.
- C – Provision for heat exchanger.
- X – Features that apply to model.

PART NO.	DESCRIPTION
<b>1. QUICK LIST -- CLAMPS, FILTER-DRIER, FUSE, TY-RAPS, AND WIRE TERMINALS</b>	
34-00373-51P10	Clamp, Tube, 1/4 – SST
34-00373-53P10	Clamp, Tube, 3/8 – SST
34-00373-05P10	Clamp, Tube, 1/2 – SST
34-00373-07P10	Clamp, Tube, 5/8 – SST
34-00373-59P10	Clamp, Tube, 3/4 – SST
34-00373-11P10	Clamp, Tube, 7/8 – SST
34-00373-65P10	Clamp, Tube, 1-1/8 – SST
34-00373-67P10	Clamp, Tube, 1-1/4 – SST
34-00373-69P10	Clamp, Tube, 1-3/8 – SST
34-00373-71P10	Clamp, Tube, 1-1/2 – SST
22-00066-01P25	Connector, Butt End, Wire Range – 22 to 16 Gauge
22-00066-02P25	Connector, Butt End, Wire Range – 16 to 14 Gauge
22-00066-03P25	Connector, Butt End, Wire Range – 12 to 10 Gauge
22-00041-00P25	Connector, Closed End, Wire Range – 22 to 14 Gauge
22-00041-02P25	Connector, Closed End, Wire Range – 18 to 10 Gauge
66U1-7472-1	Filter-Drier
HY10FJ006-P05	Fuse, 6 amp
22-00060-21P05	Fuse, 5 amp (Slow Blow)
HY10FJ203-P05	Fuse, 3 amp
22-00060-22P05	Fuse, 1 amp
22-01140-01P25	Ring Terminal, #6, Wire Range – 12 to 10 Gauge
22-01140-02P25	Ring Terminal, #10, Wire Range – 12 to 10 Gauge
22-01140-04P25	Ring Terminal, 3/8, Wire Range – 12 to 10 Gauge
22-00119-04P25	Ring Terminal, 1/4, Wire Range – 12 to 10 Gauge
22-00120-04P25	Ring Terminal, #10, Wire Range – 16 to 14 Gauge
22-00120-07P25	Ring Terminal, 5/16, Wire Range – 16 to 14 Gauge
22-00121-07P25	Ring Terminal, #10, Wire Range – 22 to 16 Gauge
22-01139-04P25	Ring Terminal, 3/8, Wire Range – 16 to 14 Gauge
22-01141-01P25	Spade Terminal, 1/4 x 5/16, Wire Range – 16 to 14 Gauge
22-00595-01P25	Spade Terminal, 3/8, Wire Range – 12 to 10 Gauge
22-01106-00F25	Spiral Wrap, 1/4 Diameter x 25 ft lg
22-01107-00F25	Spiral Wrap, 1/2 Diameter x 25 ft lg
66U1-3803P10	Tube, Heat Shrink, 1/4 ID x 2-1/8 lg
44-01043-05P25	Ty-Raps, 5-1/2 inches lg
44-01043-07P25	Ty-Raps, 11.00 inches lg
22-50007 Series	Wire Markers

## 2. TOOLS

07-00013	Temperature Tester ( <b>Simpson Meter</b> )
07-00013-01	Temperature Test Lead ( <b>15 Foot</b> )
07-00013-02	Temperature Test Lead ( <b>50 Foot</b> )
07-00013-03	Adapter, Males (Both Ends) ( <b>Use with Temperature Tester</b> )
07-00015	Case, Carrying ( <b>Used with 07-00013</b> )
07-00219	Wrench, Compressor Sight Glass
07-00221	Inspection Light with Mirror
07-00228	Volt-Ohmmeter, Digital
07-00229	Amprobe Clamp ( <b>Used with 07-00228</b> )
07-00237	Gauge Manifold Set
07-00243	Volt-Ohmmeter, Digital ( <b>Fluke</b> )
07-00254-00	Pin Extender, Plug Connector
07-00263-00	Pliers, Crimping (Used for compressor terminal block replacement)
07-00264-00	Grip, Wire Vise (Used for compressor terminal block replacement)
07-00268-00	Crimper, Micro Contact Pins

3. REFRIGERATION UNIT ASSEMBLY

3.1 REFRIGERATION UNIT -- FRONT

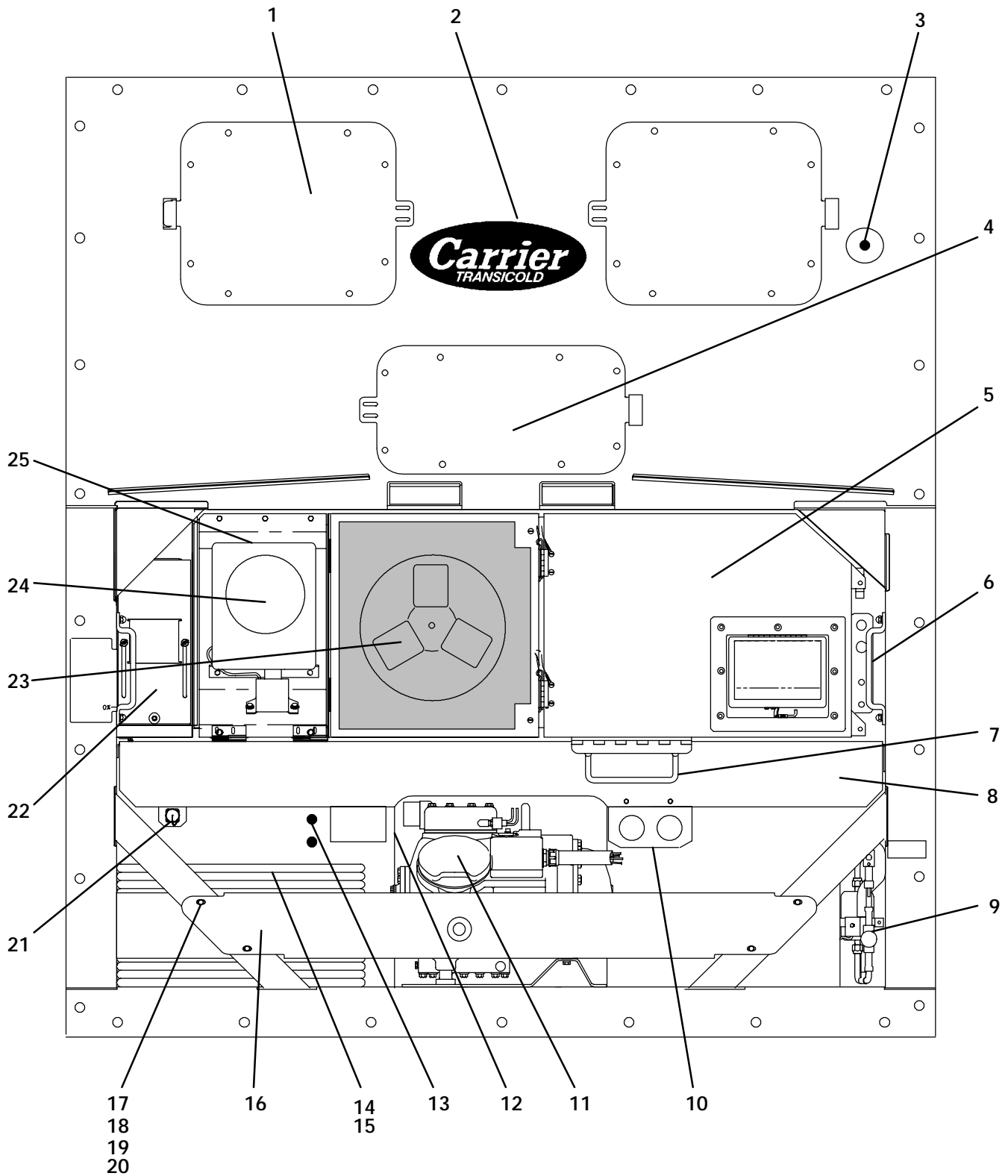

ITEM	PART NO.	DESCRIPTION	QTY
<b>3.1 REFRIGERATION UNIT -- FRONT</b>			
1	–	Panel, Access & Evaporator Fan Motor – Refer to Section 3.10	–
2	–	Labels and Decals – Refer to Section 3.21	–
3	66U1-8662	Cap & Chain <b>69NT20-274-1</b>	1
4	–	Valve, Thermostatic Expansion (Location) – Refer to Section 3.15	1
5	–	Box, Control – Refer to Sections 3.2 to 3.7	–
6	69NT35-8113	Handle (Optional)	2
7	69NT40-657	Handle, Hinged (Optional)	1
8	–	Coil, Condenser – Refer to Section 3.8	–
9	–	Receiver, Water-Cooled Condenser – Refer to Section 3.9	–
10	–	Gauge, Pressures – Refer to Section 3.18	1
11	–	Compressor – Refer to Section 3.18 or 5.	1
12	58-01213-00	Plug, Hole, 1/4	A/R
13	58-01214-00	Plug, Hole, 3/8	A/R
14	–	Cable, Power – Refer to Section 3.20	1
15	–	Plug, Power – Refer to Section 3.20	1
16	69NT35-3104-1	Guard, Compressor	1
17	PL	Capscrew, 1/4-20 x 1-1/2 lg – SST	4
18	PL	Locknut, 1/4-20 – SST	3
19	PL	Washer, Flat, 1/4 – SST	A/R
20	58-50013-02	Washer, Mylar, 1/4 ID x 3/4 OD	A/R
21	–	Connector, Interrogator – Refer to Section 4.1	–
22	–	Cover, Makeup Air – Refer to Section 3.19	1
23	–	Motor, Condenser Fan – Refer to Section 3.8	–
24	–	Recording Thermometer (Optional) – Refer to Sections 3.13 or 3.14	1
25	69NT42-544	Cover, Blank (Location) (For Unit without a Recording Thermometer)	1
NS	69NT35-8734-1	Cable Assembly, Rear (Transfresh) (NSI)	1
NS	69NT35-8734-3	Cable, Power – A2C (Transfresh) (NSI)	1
NS	69NT35-8734-4	Cable Assembly, A3C (Transfresh) (NSI)	1
NS	69NT35-8734-5	Hose Assembly, Air (Transfresh) (NSI)	1
NS	69NT35-8734-6	Fuse Assembly, In-line (Transfresh) (NSI)	1

ITEM	PART NO.	DESCRIPTION	QTY
------	----------	-------------	-----

### 3.2 CONTROL BOX DOOR

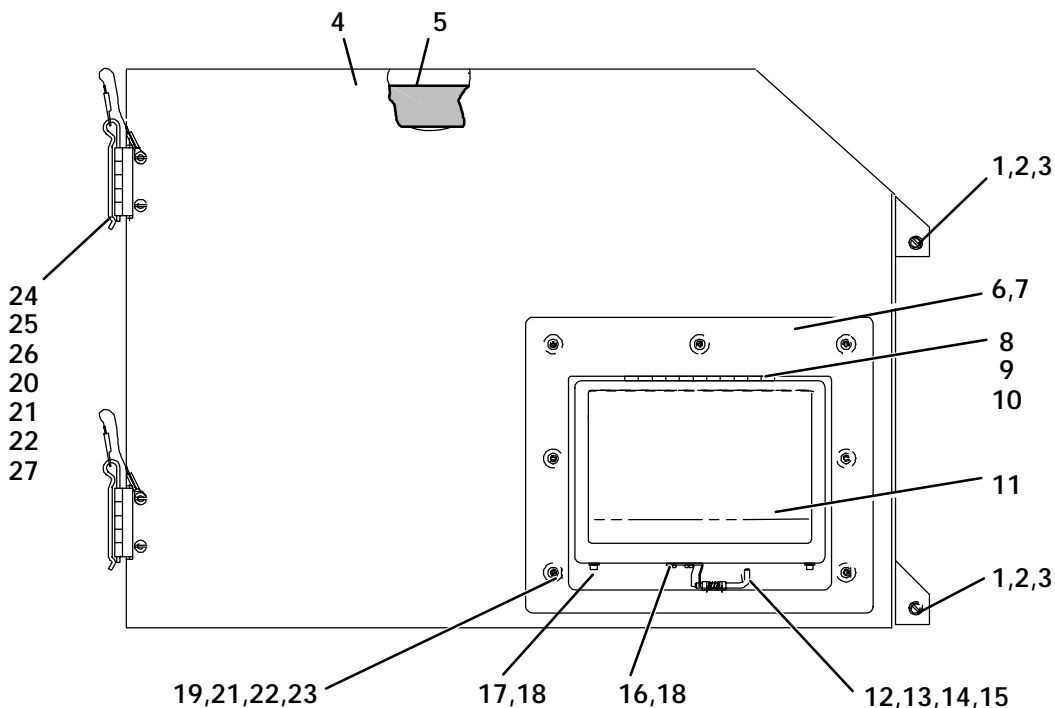

1	66U1-6811-11	Screw, Retaining	2
2	34-01226-00	Washer, Retaining	2
3	58-50013-03	Washer, Mylar	2
4	69NT42-414-5	Door Assembly – Includes:	1
4	69NT42-414-8	Door Assembly Locking <b>69NT40-454, -2, -3</b> – Includes:	1
5	42-00189-00	Gasket	1
6	69NT42-684	Door Assembly (Display) – Includes:	1
7	NSS	Bezel	1
8	44-00309-00	Hinge with Spring	1
9	66U1-6832-1	Rivet, Blind, 5/16 Diameter, Grip Range – 1/8-1/4 (NSI)	6
10	66U1-9132-1	Washer, Plain – Special	3
11	69NT42-674	Door Assembly (Display) – Includes:	1
NS	69NT35-9613	Gasket	1
12	44-01125-00	Latch	1
13	PL	Screw, Pan Head, #6-32 X 1/2 LG – SST	2
14	PL	Washer, Flat, #6 – SST	2
15	PL	Locknut, #6-32 – SST	2
16	69NT35-5732	Strike	1
17	PL	Washer, Flat, #8 – SST	2
18	PL	Locknut, #8-32 – SST	4
19	42-00201-00	Gasket (Display Bezel)	1
20	PL	Washer, Lock, #10 – SST	4
21	PL	Screw, #10-24 x 3/4 lg – SST	A/R
22	PL	Washer, Flat, #10 – SST	A/R
23	PL	Locknut, #10-24 – SST	7
NS	58-00971-00	Pocket (Inside Door)	1
24	44-01116-00	Hinge (Used on Door Assembly 69NT42-414-8)	2
24	44-00300-00	Hinge Assembly (Used on Door Assembly 69NT42-414-5) (NSI) – Includes:	2
NS	44-00300-01	Hinge, Half	1
NS	44-00300-02	Hinge, Half	1
NS	44-00300-03	Pin Assembly, with Tether	1
25	34-01167-01	Retainer	2
26	34-06053-05	Washer, Mylar	4
27	58-04101-00	Protector, Mylar (Hinge)	2



ITEM	PART NO.	DESCRIPTION	QTY
------	----------	-------------	-----

3.3 CONTROL BOX DOOR -- 69NT40-444-15

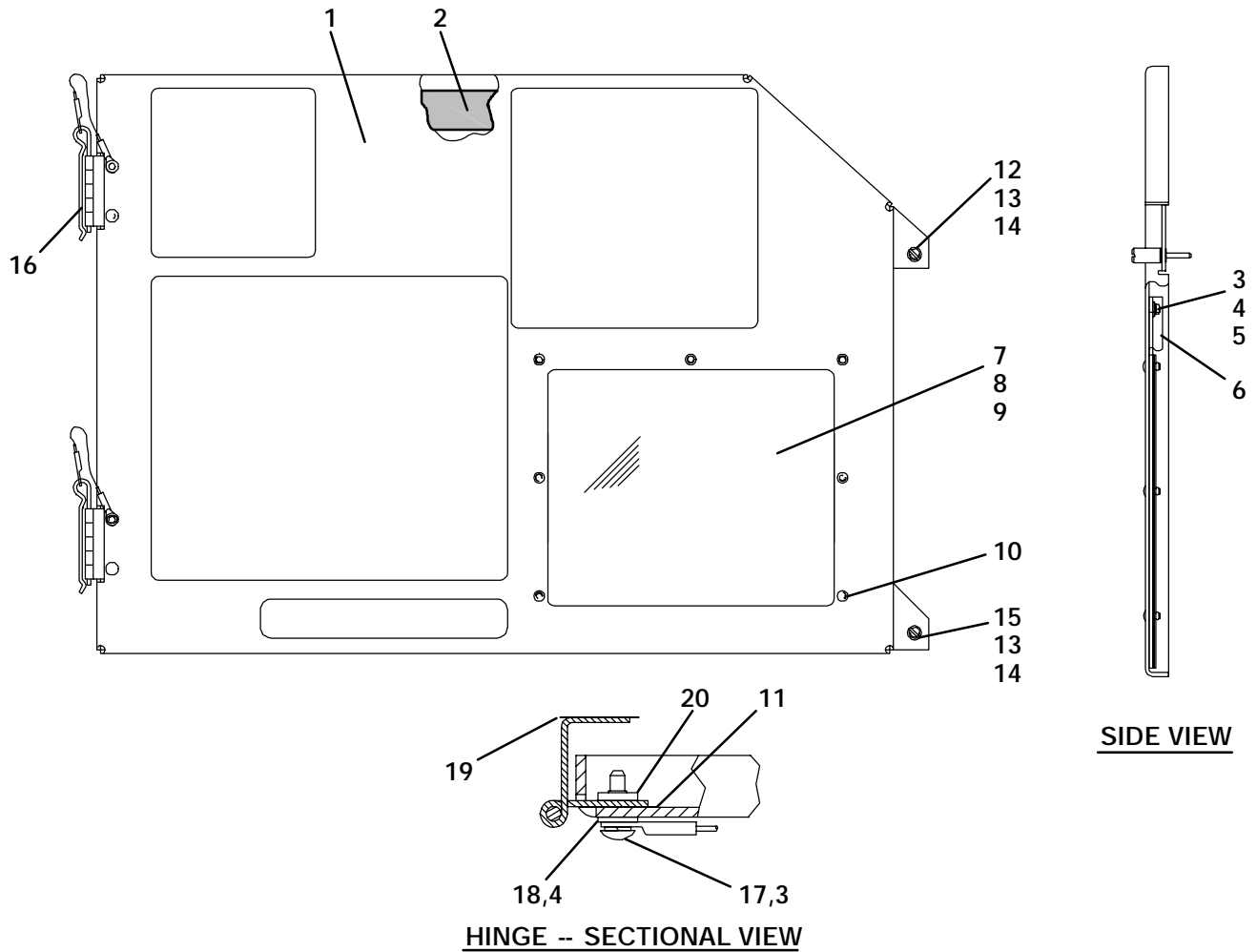

**SIDE VIEW**

**HINGE -- SECTIONAL VIEW**

1	69NT42-414-16	Door Assembly – Includes:	1
2	42-00189-01	Gasket, Door	1
3	66U1-5331-3	Washer, Lock, #10 – SST (NSI)	47
4	66U1-5321-8	Washer, Flat, #10 – SST (NSI)	7
5	34-00665-09	Locknut, #10-32 – SST (NSI)	3
6	58-00971-00	Pocket, Schematic and Diagram (Inside Door)	1
7	58-04123-00	Window, Lexan, 10.48 x 12.62 x .125 thick (NSI)	1
8	42-00262-00	Gasket (Used between window and backup plate)	1
9	69NT35-1927	Plate, Backup, 5/8 thick – Aluminium (NSI)	1
10	34-00774-04	Rivet, Blind, 3/16 Diameter, Grip Range – 1/4-5/8 (NSI)	7
11	58-04101-00	Protector, Mylar, Hinge (Used between hinge and door)	2
12	66U1-6811-11	Screw, Retaining	1
13	34-01226-00	Washer, Retaining	2
14	58-50013-02	Washer, Mylar	2
15	66U1-6811-10	Screw, Retaining	1
16	44-00300-00	Hinge Assembly (NSI) – Includes:	2
NS	44-00300-01	Hinge, Half	1
NS	44-00300-02	Hinge, Half	1
NS	44-00300-03	Pin Assembly, w/Tether	1
17	66U1-2403-1	Screw, #10-24 x 3/4 lg – SST (NSI)	4
18	34-06053-05	Washer, Mylar	4
19	58-04101-01	Protector, Mylar, Hinge (Used between hinge and unit frame) (NSI)	2
20	34-01167-01	Retaining, Nut	2

---

3.4 CONTROL BOX

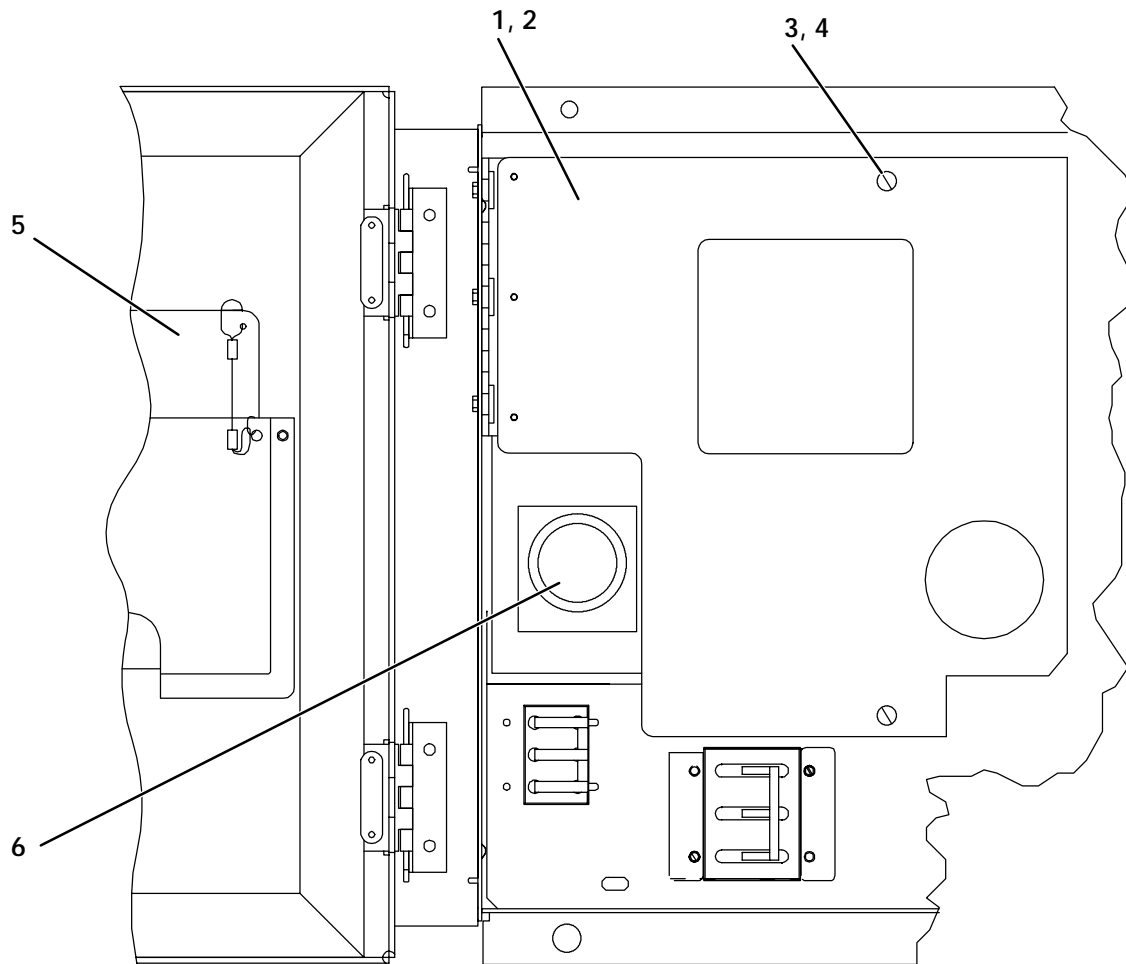

ITEM	PART NO.	DESCRIPTION	QTY
<b>3.4 CONTROL BOX</b>			
1	69NT40-907	Shield, High Voltage – Includes:	1
1	69NT40-907-1	Shield, High Voltage <b>69NT40-444-15</b> – Includes:	1
2	44-00297-00	Hinge	1
3	66U1-3442-2	Stud, 1/4 Turn	2
4	66U1-9212-1	Retainer	2
5	69NT20-373-91	Plate, Schematic & Diagram (NSI) – <b>69NT40-444, -2</b>	1
5	69NT20-373-92	Plate, Schematic & Diagram (NSI) – <b>69NT40-444-1</b>	1
5	69NT20-373-93	Plate, Schematic & Diagram (NSI) – <b>69NT40-444-4</b>	1
5	69NT20-373-95	Plate, Schematic & Diagram (NSI) – <b>69NT40-444-3</b>	1
5	69NT20-373-94	Plate, Schematic & Diagram (NSI) – <b>69NT40-454</b>	1
5	69NT20-373-97	Plate, Schematic & Diagram (NSI) – <b>69NT20-274</b>	1
5	69NT20-373-96	Plate, Schematic & Diagram (NSI) – <b>69NT20-274-1</b>	1
5	69NT20-373-101	Plate, Schematic & Diagram (NSI) – <b>69NT40-444-6</b>	1
5	69NT20-373-104	Plate, Schematic & Diagram (NSI) – <b>69NT40-454-1</b>	1
5	69NT20-373-105	Plate, Schematic & Diagram (NSI) – <b>69NT40-444-7, -8</b>	1
5	69NT20-373-106	Plate, Schematic & Diagram (NSI) – <b>69NT40-444-9</b>	1
5	69NT20-373-109	Plate, Schematic & Diagram (NSI) – <b>69NT40-444-10</b>	1
5	69NT20-373-110	Plate, Schematic & Diagram (NSI) – <b>69NT40-444-11</b>	1
5	69NT20-373-114	Plate, Schematic & Diagram (NSI) – <b>69NT40-444-12</b>	1
5	69NT20-373-115	Plate, Schematic & Diagram (NSI) – <b>69NT40-454-2, -3</b>	1
5	69NT20-373-118	Plate, Schematic & Diagram (NSI) – <b>69NT40-444-13</b>	1
5	69NT20-373-119	Plate, Schematic & Diagram (NSI) – <b>69NT20-274-2</b>	1
5	69NT20-373-120	Plate, Schematic & Diagram (NSI) – <b>69NT40-444-14</b>	1
5	69NT20-373-122	Plate, Schematic & Diagram (NSI) – <b>69NT40-444-16</b>	1
5	69NT20-373-123	Plate, Schematic & Diagram (NSI) – <b>69NT40-444-15</b>	1
5	69NT20-373-125	Plate, Schematic & Diagram (NSI) – <b>69NT40-444-17</b>	1
5	69NT20-373-138	Plate, Schematic & Diagram (NSI) – <b>69NT20-274-3</b>	1
5	69NT20-373-127	Plate, Schematic & Diagram (NSI) – <b>69NT40-444-18</b>	1
5	69NT20-373-137	Plate, Schematic & Diagram (NSI) – <b>69NT40-444-19</b>	1
5	69NT20-373-133	Plate, Schematic & Diagram (NSI) – <b>69NT40-441-21 &amp; 69NT40-444-21</b>	1
5	69NT20-373-135	Plate, Schematic & Diagram (NSI) – <b>69NT40-444-20, -22, -23 &amp; 69NT40-441-22, -23, -25</b>	1
5	69NT20-373-140	Plate, Schematic & Diagram (NSI) – <b>69NT40-441-24</b>	1
6	66U1-3823	Meter, Hour – Optional	1
6	66U1-3823-1	Meter, Hour (Resettable) – Optional	1

ITEM	PART NO.	DESCRIPTION	QTY
------	----------	-------------	-----

3.5 CONTROL BOX -- HIGH VOLTAGE SHIELD REMOVED

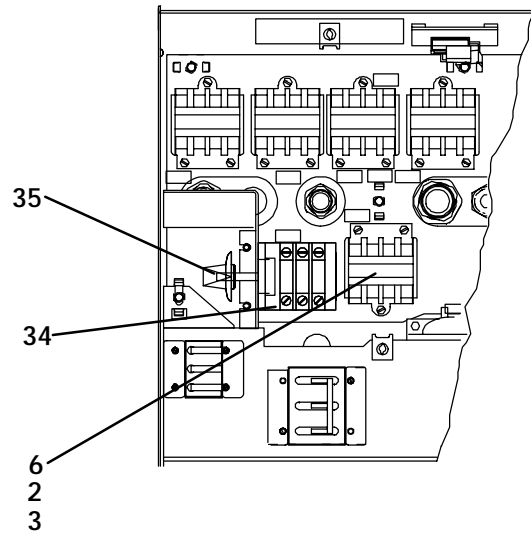

UNITS WITH TWO-SPEED EVAPORATOR MOTOR

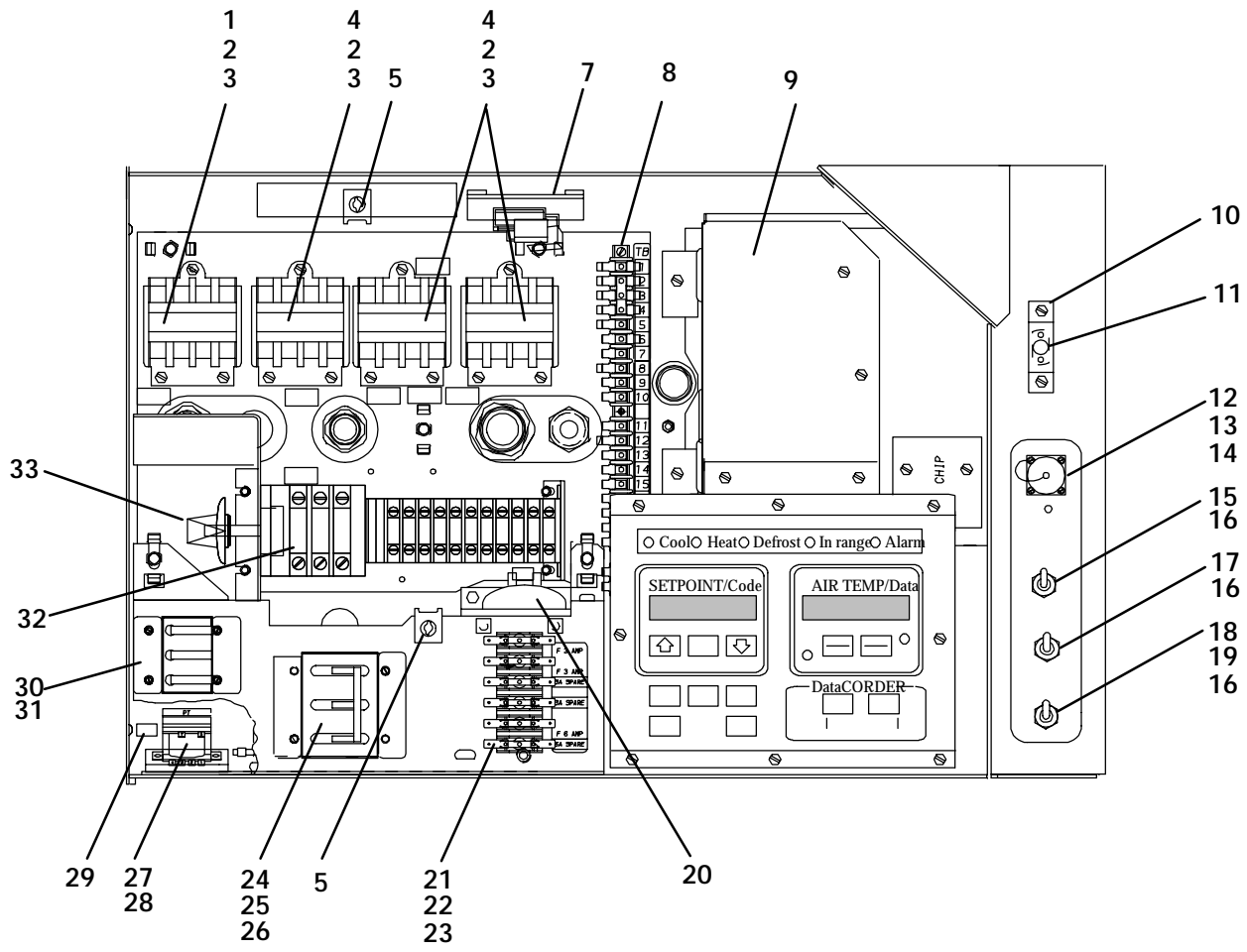

UNITS WITH ONE-SPEED EVAPORATOR MOTOR

ITEM	PART NO.	DESCRIPTION	QTY
<b>3.5 CONTROL BOX -- HIGH VOLTAGE SHIELD REMOVED</b>			
1	10-00304-33	Contactora, Compressor ( <b>40 Amp</b> )	1
1	10-00304-00	Contactora, Compressor ( <b>60 Amp</b> )	1
2	PL	Screw, Hex Head, #10-24 x 1/2 lg – SST	A/R
3	PL	Washer, Lock, #10 – SST	A/R
4	10-00304-32	Contactora, Heater, Condenser & Evaporator Fan Motor (EF)	3
5	66U1-9222	Receptacle, Retaining (For High Voltage Shield)	2
6	10-00304-32SV	Contactora, Evaporator Fan Motor (ES) – Includes:	2
NS	10-00304-32	Contactora	1
NS	10-00304-40	Contactora, Auxiliary	1
7	10-50016-00	Kit, Transformer Current	3
8	22-01553-00	Block, Terminal (NSI)	1
9	–	Controller Box, Microprocessor – Refer to Section 3.6 – Includes:	1
10	69NT35-9453	Bracket (Latch/Lock) – Optional (NSI)	1
11	34-01142-01	Receptacle, Retaining (For Control Box Door)	2
12	22-02341-00	Receptacle, Remote Monitoring (Plastic) – Optional	1
13	22-02341-01	Cap and Chain (RM) – Optional	1
14	66U1-6835	Gasket, Receptacle – Optional	1
15	10-00298-01	Switch, Toggle (CFS) – <b>69NT40-454, -2, -3</b>	1
15	10-01130-07	Switch, Toggle (BMS) – <b>69NT40-444-3, -7, -8</b>	1
16	66U1-9752	Seal, Bushing	A/R
17	10-00221	Switch, Toggle (MDS)	1
18	10-00237	Switch, Toggle (On-Off)	1
18	66U1-3683-1	Switch, Toggle – <b>Circuit Breaker 8 Amp</b> (On-Off)	1
19	69NT35-6722	Adapter Strip (Used with Circuit Breaker) (NSI)	1
20	66U1-2353	Transformer, Control	1
21	22-02381-00	Fuse Block	1
22	HY10FJ006	Fuse, 6 amp	2
23	22-00060-21	Fuse, 5 amp (Slow Blow)	4
24	66U1-1723-2	Circuit Breaker – CB-1 460 vac ( <b>69NT20</b> )	1
24	66U1-1723-3	Circuit Breaker – CB-1 460 vac ( <b>69NT40</b> )	1
25	PL	Screw, Pan Head, #6-32 x 7/16 lg – SST	A/R
26	PL	Washer, Lock, #6 – SST	4
27	10-01158-00	Transformer, Potential	1
28	58-01217-00	Spacer	1
29	66CH1-1002-100	Label, Potential Transformer (PT) (NSI)	2
30	66U1-4522-2	Circuit Breaker – 230vac (CB-2) – Optional	1
30	10-00277-00	Circuit Breaker – 250vac 50 amp (CB-2) – <b>69NT40-441-21, -22, -23, -25</b> <b>69NT40-444-18, -19, -20, -22, -23</b>	1
31	58-00974-00	Plate (CB-2) (NSI)	1
32	10-01148-01	Switch, Voltage ( <b>14 Station</b> ) – ( <b>Grey or White Body</b> )	1
33	10-01148-04	Handle ( <b>For P/N 10-01148-01</b> ) – Includes:	1
NS	10-01148-04SV	Tightening Element ( <b>For P/N 10-01148-04</b> )	1
32	10-00331-00	Switch, Voltage ( <b>14 Station</b> ) – ( <b>Green Body</b> ) <b>Starting with S/N 90180838</b> – Includes:	1
33	10-00331-21	Handle ( <b>For P/N 10-00331-00</b> ) – Includes:	1
NS	NSS	Screw, Handle ( <b>For P/N 10-00331-21</b> )	1
34	10-01149-01	Switch, Voltage ( <b>3 Station</b> )	1
35	10-01149-04	Knob ( <b>For 3 Station</b> ) – Includes:	1
NS	10-01149-04SV	Tightening Element	1

3.6 CONTROL BOX -- MICROPROCESSOR CONTROLLER BOX

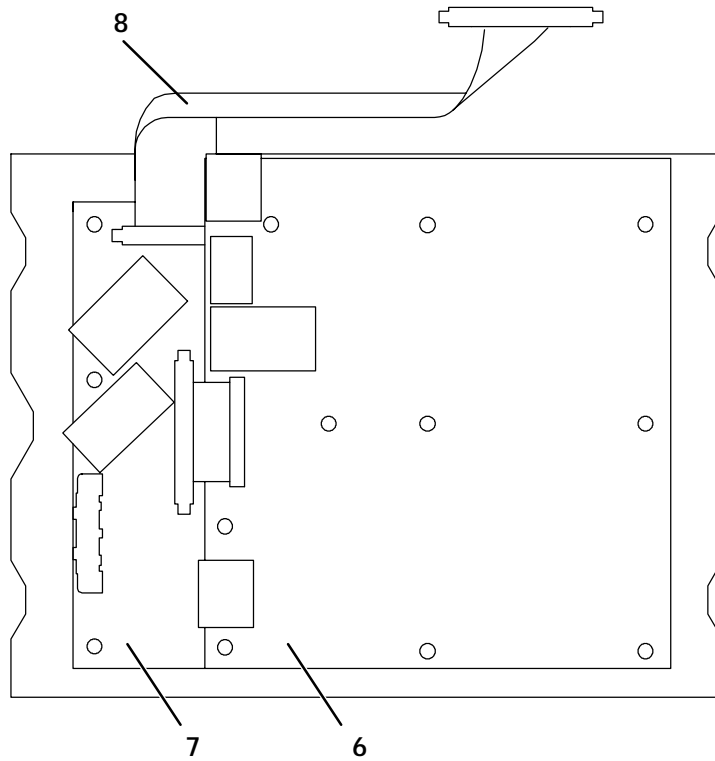
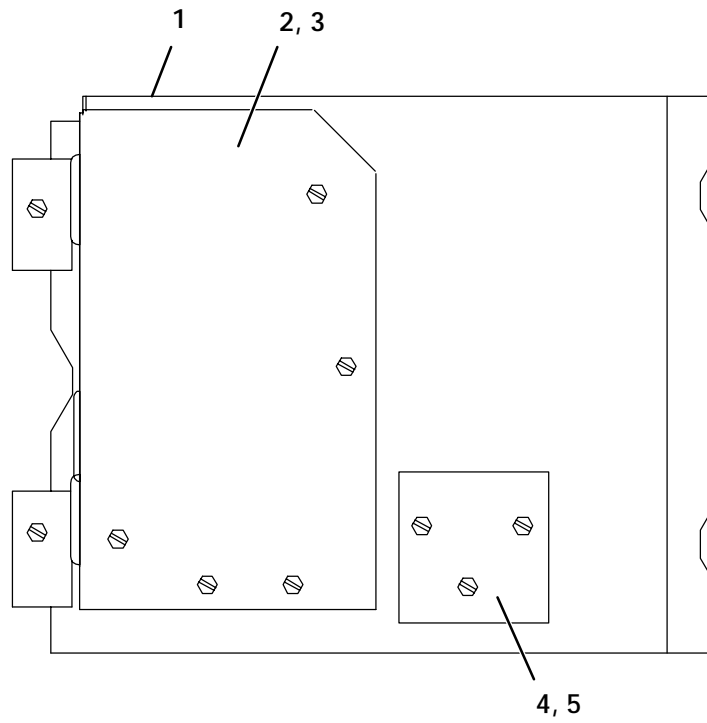

COVERS REMOVED

ITEM	PART NO.	DESCRIPTION	QTY
<b>3.6 CONTROL BOX -- MICROPROCESSOR CONTROLLER BOX</b>			
*1	69NT42-334-50	Controller Box, Micro <b>69NT40-444, -2, -9, -11, -12, -13, -14, -16</b> – Includes:	1
*1	69NT42-334-51	Controller Box, Micro <b>69NT40-444-1</b> – Includes:	1
*1	69NT42-334-52	Controller Box, Micro <b>69NT40-444-4, -6</b> – Includes:	1
*1	69NT42-334-53	Controller Box, Micro <b>69NT40-444-3, -7, -8, &amp; -454, -2, -3</b> – Includes:	1
*1	69NT42-334-55	Controller Box, Micro <b>69NT20-274-1</b> – Includes:	1
*1	69NT42-334-56	Controller Box, Micro <b>69NT20-274, -2</b> – Includes:	1
*1	69NT42-334-60	Controller Box, Micro <b>69NT40-444-10, -21</b> – Includes:	1
*1	69NT42-334-61	Controller Box, Micro <b>69NT40-454-1</b> – Includes:	1
*1	69NT42-334-62	Controller Box, Micro <b>69NT40-444-15</b> – Includes:	1
*1	69NT42-334-63	Controller Box, Micro <b>69NT40-444-17</b> – Includes:	1
*1	69NT42-334-64	Controller Box, Micro <b>69NT40-441-24, &amp; -444-18, -19</b> – Includes:	1
*1	69NT42-334-65	Controller Box, Micro <b>69NT40-444-20, -22, -23 &amp; 69NT40-441-21, -22, -23, -25</b> – Includes:	1
*1	69NT42-334-68	Controller Box, Micro <b>69NT20-274-3</b> – Includes:	1
2	69NT40-897-SV	Cover – Includes:	1
3	69NT35-6372	Gasket	1
4	69NT35-6192-SV	Plate – Includes:	1
5	69NT35-6332	Gasket	1
6	12-00298-00	Board, Logic – NEW	1
6	12-00298-20	Board, Logic – Remanufactured	1
6	12-00298-03	Board, Logic – NEW <b>69NT40-454-1 &amp; 69NT40-444-17</b>	1
6	12-00298-23	Board, Logic – Remanufactured <b>69NT40-454-1 &amp; 69NT40-444-17</b>	1
6	12-00298-04	Board, Logic – NEW <b>69NT20-274-3 &amp; 69NT40-444-18, -19, -20, -22, -23 &amp; 69NT40-441-21, -22, -23, -24, -25</b>	1
6	12-00298-24	Board, Logic – Remanufactured <b>69NT20-274-3 &amp; 69NT40-444-18, -19, -20, -22, -23 &amp; 69NT40-441-21, -22, -23, -24, -25</b>	1
6	12-00297-00	Board, Logic – NEW <b>69NT20-274-1</b>	1
6	12-00297-20	Board, Logic – Remanufactured <b>69NT20-274-1</b>	1
7	12-01123-00SV	Board, I/O – NEW	1
7	12-01123-20SV	Board, I/O – Remanufactured	1
8	12-00271-00	Cable, Ribbon	1
NS	76-50022-00	Kit Gaskets, Cover	1
NS	76-50023-00	Kit Gaskets, Controller Box	1

\* NOTE: Indicates the items that may be order as remanufactured parts by adding RM to the end of the part number. Example 69NT42-334-6RM is a remanufactured 69NT42-334-6.

3.7 CONTROL BOX -- MICROPROCESSOR CONTROLLER BOX -- COVER REMOVED

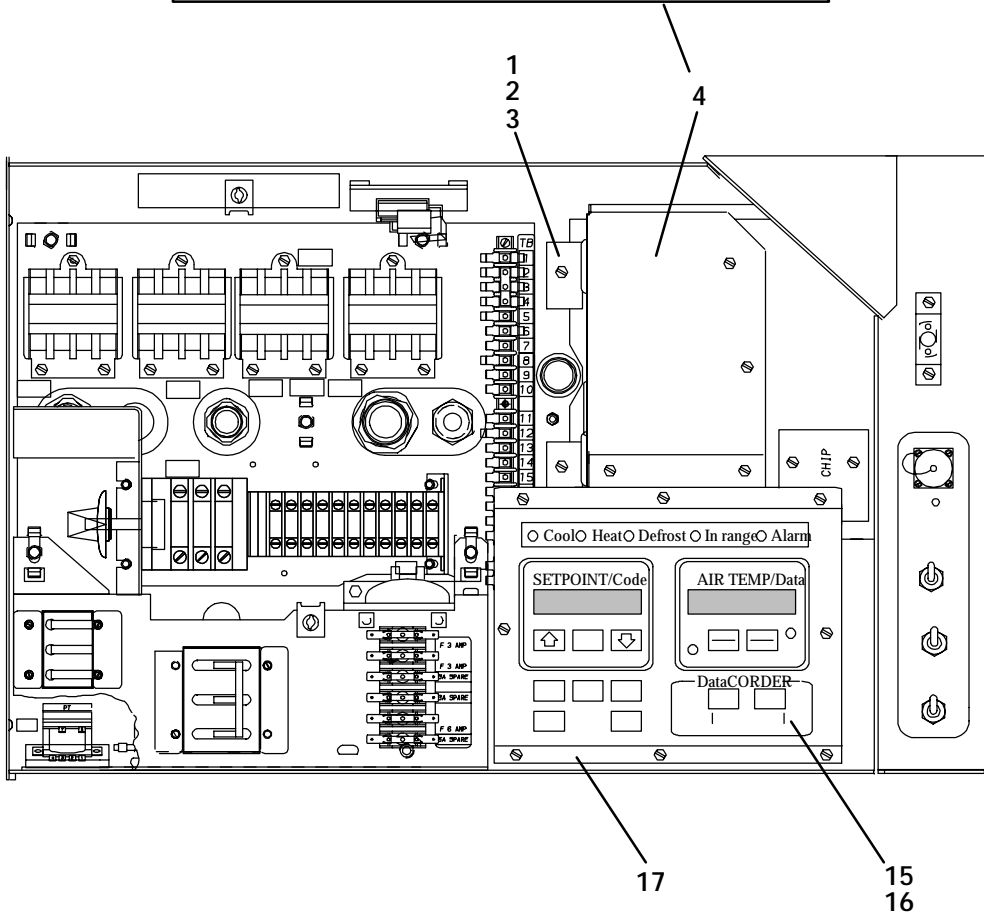
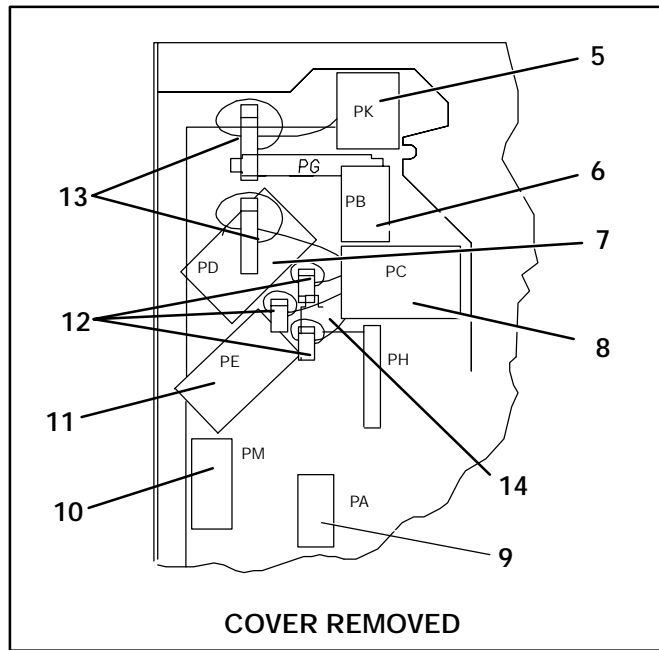



ITEM	PART NO.	DESCRIPTION	QTY
<b>3.7 CONTROL BOX -- MICROPROCESSOR CONTROLLER BOX -- COVER REMOVED</b>			
1	58-00965-00	Spacer, Nylon	2
2	PL	Washer, Flat, 1/4 – SST	2
3	PL	Capscrew, Hex Head, 1/4-20 x 1-1/4 lg – SST	2
4	69NT40-897-SV	Cover – Includes:	1
NS	69NT35-6372	Gasket	1
5	22-02355-03SV	Connector, Plug (PK) – Includes:	1
NS	22-02362-01	Socket, Terminal	9
6	22-02355-00SV	Connector, Plug (PB) – Includes:	1
NS	22-02362-00	Socket, Terminal	6
7	22-02357-00SV	Connector, Plug (PD) – Includes:	1
NS	22-02361-01	Socket, Terminal	24
8	22-02355-01SV	Connector, Plug (PC) – Includes:	1
NS	22-02362-01	Socket, Terminal	24
9	22-02357-02SV	Connector, Plug (PA) – Includes:	1
NS	22-02361-01	Socket, Terminal	9
10	22-02306-00	Connector, Plug (PM) – Includes:	1
NS	22-02362-00	Socket, Terminal	6
11	22-02355-02SV	Connector, Plug (PE) – Includes:	1
NS	22-02362-01	Socket, Terminal	18
11	22-02355-04SV	Connector, Plug (PE) <b>69NT20-274-1</b> – Includes:	1
NS	22-02362-01	Socket, Terminal	12
12	22-02416-01	Suppressor, RFI, 0.31 I.D.	3
13	22-02416-00	Suppressor, RFI, 0.76 I.D.	2
14	22-02416-02	Suppressor, RFI, 0.50 I.D. (Location)	1
15	12-00313-00SV	Display Assembly, Digital – Includes:	1
NS	42-01094-00	Gasket	1
NS	12-01084-01	Keypad	1
NS	12-01116-02	Board, Digital Display – <b>NEW</b> (NSI)	1
NS	12-01116-22	Board, Digital Display – <b>Remanufactured</b> (NSI)	1
NS	12-00313-01	Board, Annunciator	1
NS	69NT40-817	Cover Assembly, Digital Display (Back cover) (NSI)	1
16	12-00271-00	Ribbon Cable Assembly, Digital Display	1
17	44-00298-00	Hinge, Digital Display	1
NS	12-00275-00	Communication Module (RMU) (NSI)	1
NS	22-02396-00	Connector, Plug <b>3 Contacts</b> (RMU) (NSI)	1
NS	22-02396-02	Connector, Plug <b>5 Contacts</b> (RMU) (NSI)	1
NS	22-01556-00	Connector, Plug (RMU) (NSI)	1
NS	69NT40-927-1	Cable Assembly (RMU) (NSI)	1
		<b>69NT40-444-16, -18, -19 &amp; 69NT40-454, -2, -3</b>	1
NS	69NT40-927	Cable Assembly, RMU (NSI)	1

### 3.8 CONDENSER FAN MOTOR AND COIL SECTION

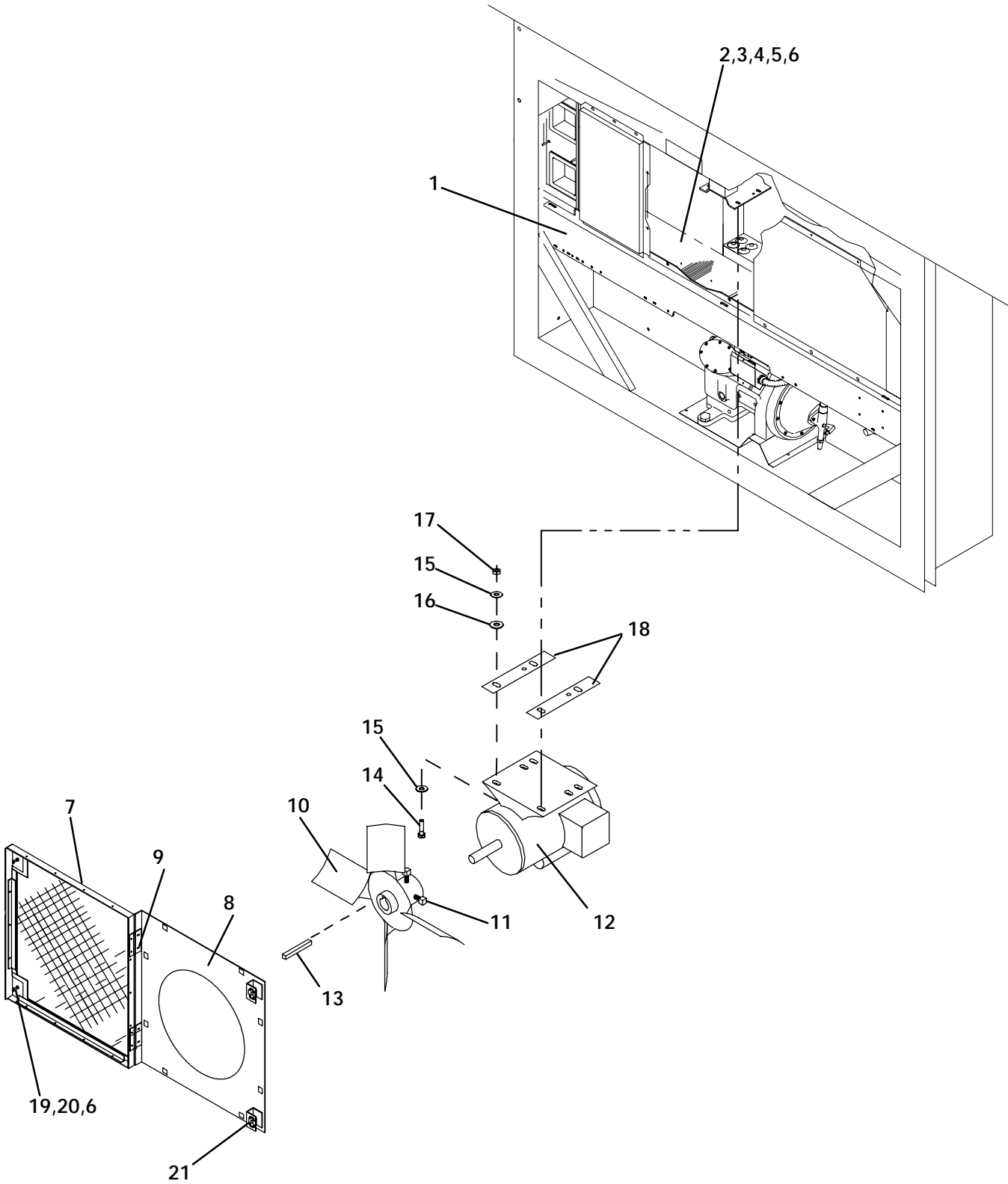

ITEM	PART NO.	DESCRIPTION	QTY
<b>3.8 CONDENSER FAN MOTOR AND COIL SECTION</b>			
1	69NT42-244	Cover, Condenser Coil	1
2	69NT42-108-SV	Coil, Condenser (Copper) – Includes Mylar Washers	1
NS	69NT35-8703	Protector (Apply between frame and coil & coil cover)	4
3	66U1-5361-25	Capscrew, Hex Head, 1/4-20 x 3/4 lg – SST (NSI)	10
4	66U1-5321-7	Washer, Flat, 1/4 – SST	10
5	58-50013-02	Washer, Mylar, 1/4 ID X 3/4 OD	10
6	58-50013-04	Washer, Mylar, 1/4 ID X 1.00 OD	2
NS	34-06053-05	Washer, Mylar, 13/64 ID X 39/64 OD	2
NS	58-04026-00	Protector, Mylar (Apply between coil mounting & frame RH side)	1
NS	58-04026-03	Protector, Mylar (Apply to top side center coil mounting)	1
NS	58-04026-04	Protector, Mylar (Apply between coil mounting & frame, RH & LH sides)	2
NS	58-04026-06	Protector, Mylar (Apply to center between frame & coil & coil cover)	2
NS	58-04026-08	Protector, Mylar (Apply to top side of coil bracket, RH & LH sides)	2
NS	58-04026-09	Protector, Mylar (Apply under coil center bracket attached to frame)	1
NS	58-04026-10	Protector, Mylar (Apply between coil & coil cover, RH & LH sides)	2
NS	58-04026-11	Protector, Mylar (Apply between coil mounting & frame LH side)	1
7	69NT40-847-2	Grille	1
7	69NT35-7944	Grille <b>69NT40-444-4, -6, -14, -15</b>	1
8	69NT40-837	Venturi ( <b>For 16.00 diameter Fan</b> )	1
8	69NT40-837-1	Venturi ( <b>For 17-1/2 diameter Fan</b> )	1
NS	PL	Rivet, Blind, 5/32 Diameter, Grip Range–1/8-5/8– SST	4
9	69NT35-1482	Hinge	2
NS	PL	Rivet, Blind, 5/32 Diameter, Grip Range–1/8-1/4– SST	4
10	38-00142-00	Fan, Condenser ( <b>16.00 diameter</b> ) – SST – Includes:	1
10	38-00511-00	Fan, Condenser ( <b>16.00 diameter</b> ) (Painted Steel)– Includes:	1
10	38-00142-01	Fan, Condenser ( <b>17-1/2 diameter</b> ) – SST – Includes:	1
10	38-00510-00	Fan, Condenser ( <b>17-1/2 diameter</b> ) (Painted Steel)– Includes:	1
10	38-00503-00	Fan, Condenser (Plastic) <b>69NT40-444-8</b> – Includes:	1
11	PL	Set Screw, Square Head, 5/16-24 x 5/8 lg – SST	2
12	54-00516-00	Motor, Condenser Fan	1
12	54-00132-00SV	Motor, Condenser Fan (NLO) – Includes:	1
13	34-00672	Key, 3/16 Square x 1-1/4 lg – SST	1
NS	22-50071-00	Capacitor	1
NS	54-50042-00	End Bell	1
14	66U1-5361	Screw, Hex Head/Washer, 5/16-18 x 1-1/4 lg – SST (NSI)	4
15	34-01181-01	Washer, Flat, 5/16 – SST (NSI)	8
16	58-50013–00	Washer, Mylar	4
17	34-00667-12	Locknut, 5/16-18 – SST (NSI)	4
18	69NT35-6112	Protector, Condenser Fan Motor Mounting	2
19	34-01150-04	Stud, 1/4 Turn	2
20	34-01150-30	Washer, Retaining	2
21	34-01150-31	Receptacle	2

3.9 WATER-COOLED CONDENSER/RECEIVER AND TUBING SECTION

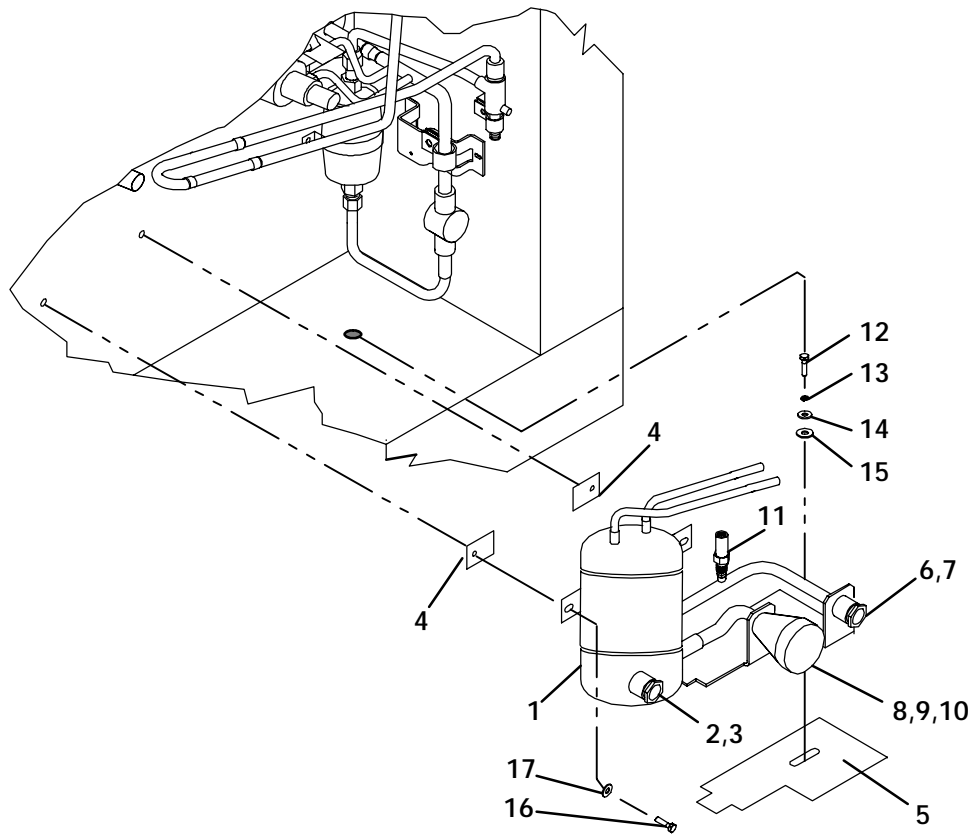

UNITS WITH WATER-COOLED RECEIVER

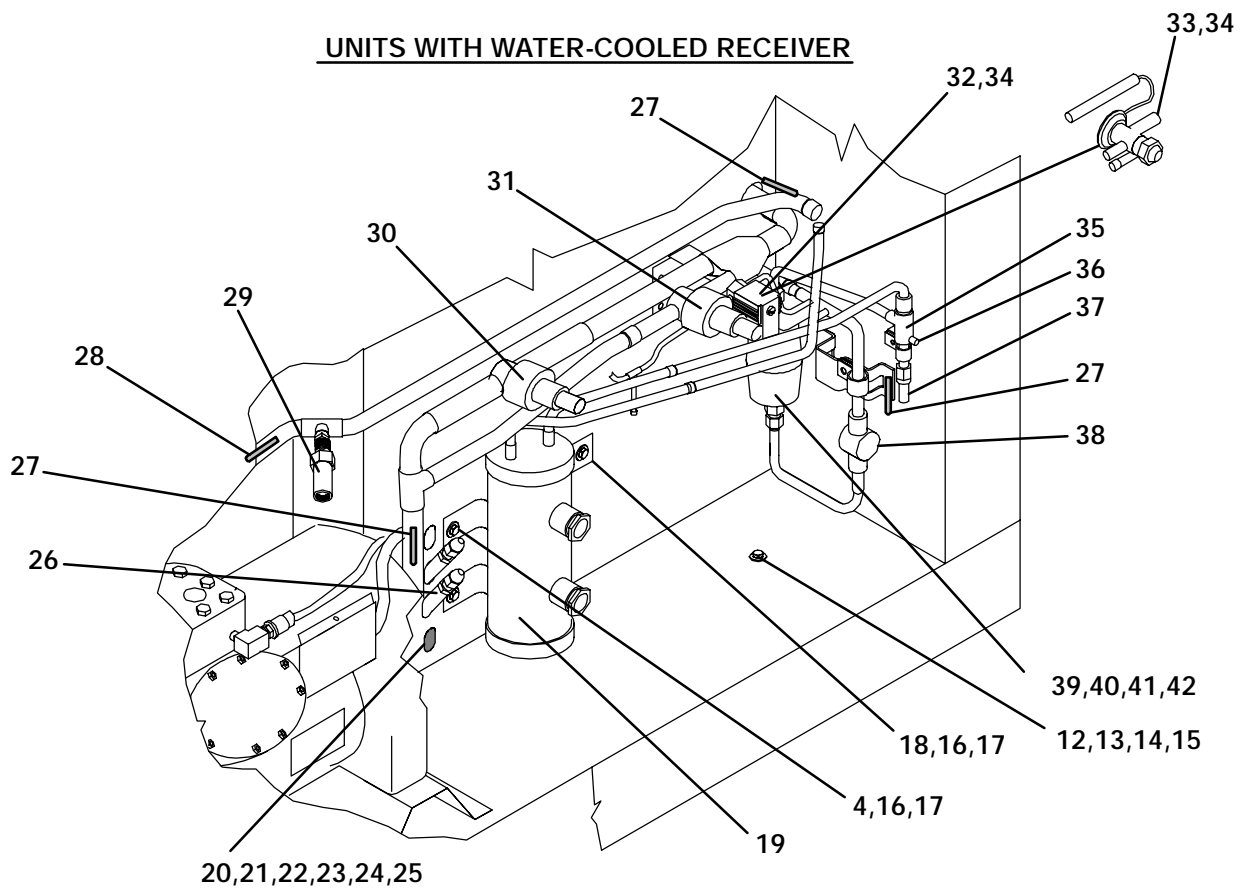

UNITS WITH RECEIVER

ITEM	PART NO.	DESCRIPTION	QTY
<b>3.9 WATER-COOLED CONDENSER/RECEIVER AND TUBING SECTION</b>			
1	69NT42-128	Condenser/Receiver ( <b>SST</b> ) – Includes: Items 2 & 3	1
NS	69NT42-914	Kit, Condenser/Receiver (Optional) – Includes:	A/R
1	69NT42-914-1	Condenser/Receiver – Includes:	1
2	14-00111	Sight Glass – Includes:	1
3	NSS	Ball, Float	1
4	58-00956-00	Protector, Mylar	2
5	58-00957-00	Protector, Mylar	1
6	66U1-2763-5	Coupling (Water-In)	1
7	66U2-1142	Cap, Dust	1
8	40-01129	Coupling, Self Draining – Includes:	1
9	42-50000	Seal, O-Ring	1
10	66U2-1152	Cap, Dust	1
11	12-01071-01SV	Switch, Water Pressure	1
8	66U1-2763-6	Coupling, Socket <b>69NT40-454, -2, -3</b>	1
12	66U1-5361-7	Bolt, Hex Head, 3/8-16 x 1.00 lg – SST (NSI)	1
13	66U1-5321-5	Washer, Flat, 3/8 – SST (NSI)	1
14	AU11JR241	Washer, Lock, 3/8 – SST	1
15	58-50013-00	Washer, Mylar, 3/8 ID x 1.00 OD	1
16	66U1-5361-25	Capscrew, Hex Head, 1/4-20 x 3/4 lg – SST (NSI)	A/R
17	66U1-5321-7	Washer, Flat, 1/4 – SST	A/R
18	58-04026-05	Protector	1
19	69NT40-937	Receiver (Optional) – Painted Steel	1
19	69NT40-977-1	Receiver (Optional) – SST	1
20	58-00991-00	Cap, Dust (Optional)	1
21	40-00466-00	Coupling, Nitrogen Feed (NSI) (Optional)	1
22	40-00468-00	Reducer (NSI) (Optional)	1
23	69NT35-9283	Bracket, Nitrogen Feed (NSI) (Optional)	1
24	58-00989-01	Protector, Mylar (Optional)	1
25	58-00989-02	Protector, Mylar (Optional)	1
26	–	Sensor Assembly – Refer to Section 6	–
27	12-01104-00	Sensor, Thermistor (AMBS, CPSS & CSAS)	3
28	12-01105-00	Sensor, Thermistor (CPDS)	1
29	14-00195-00	Valve, High Side Pressure Relief -- <b>Used on Units with Provision for R-22</b>	1
NS	14-00195-01	Valve, High Side Pressure Relief -- <b>Used on Units without Provision for R-22</b>	1
NS	14-00195-03	Valve, Pressure Relief -- <b>69NT40-441-25</b>	1
30	–	Valve, Modulating Solenoid – Refer to Section 3.17	1
31	–	Valve, Suction Solenoid – Refer to Section 3.16	1
32	14-01090-01	Valve, Quench ( <b>Solenoid</b> )	1
33	14-00189-00	Valve, Quench ( <b>Thermostatic Expansion</b> )	1
34	14-01091-01	Coil	1
35	66U1-8552	Valve, Liquid Line – Includes:	1
36	40-00086-04	Cap, Flare – 1/4	1
37	17-21002-01	Cap, Valve	1
38	14-00202-00	Indicator, Moisture – Liquid	1
39	66U1-7472-1	Filter-Drier	1
40	69NP20-1031	Clamp – Includes:	1
NS	58-50014-00F16	Gasket (16 ft, Cut to length)	A/R
41	34-06053-03	Screw, Hex Head, 1/4-20 x 3/4 lg (NSI)	2
42	58-50013-04	Washer, Mylar, 1/4 ID x 1.00 OD	2

### 3.10 EVAPORATOR FAN MOTOR AND ACCESS PANEL SECTION

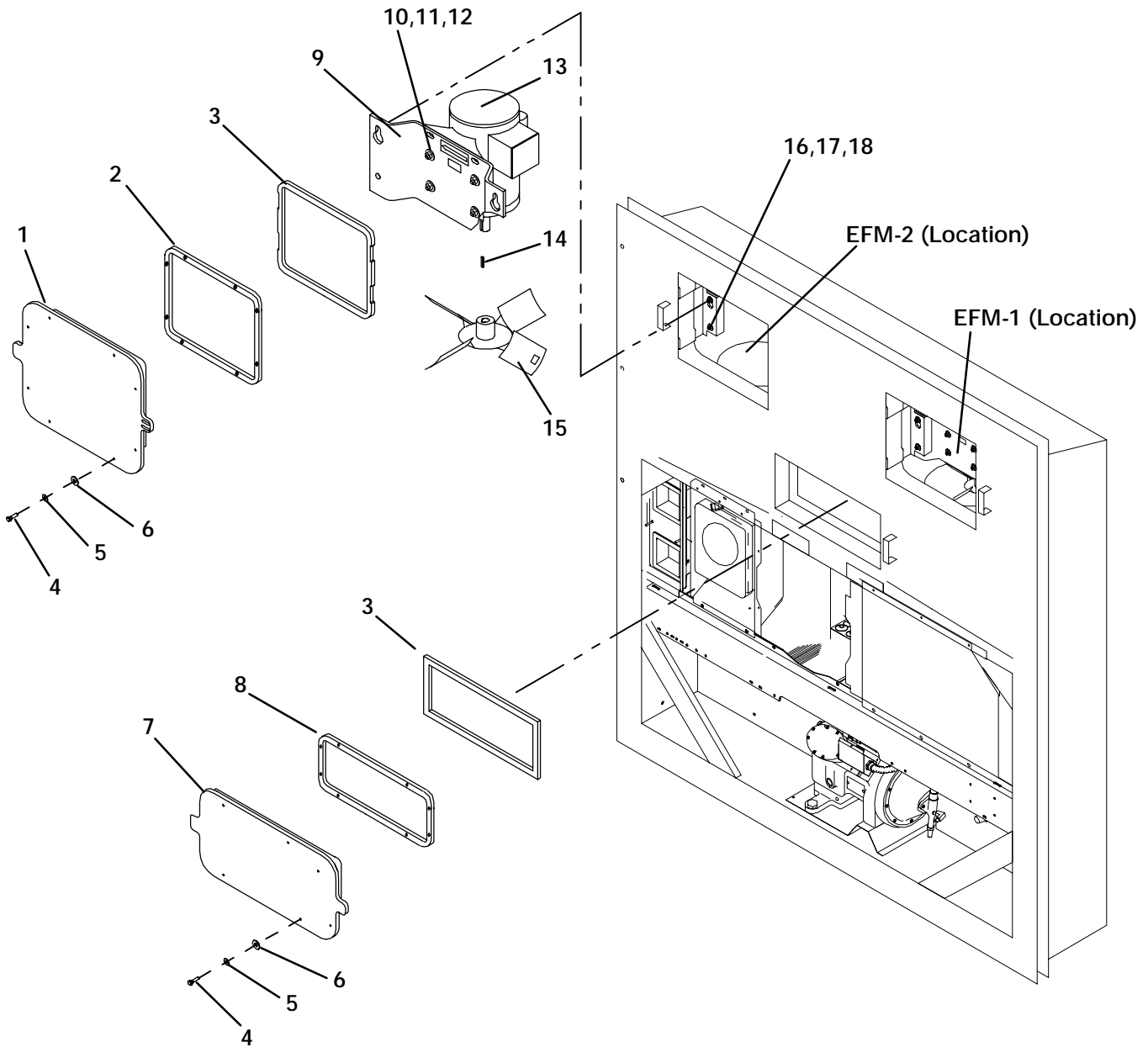

ITEM	PART NO.	DESCRIPTION	QTY
<b>3.10 EVAPORATOR FAN MOTOR AND ACCESS PANEL SECTION</b>			
1	69NT40-908-1	Panel, Access – Includes:	2
1	69NT40-908-4	Panel, Access <b>69NT40-454, -1, -2, -3</b> – Includes:	2
2	42-01082	Gasket	1
3	66U1-8115-F20	Gasket, Access Panel Seal – Adhesive Back, Pressure Sensitive, 4 x 1/2 thick (20 ft, Cut to length)	A/R
4	AA06JA170	Capscrew, Hex Head, 1/4-20 x 1 lg – SST	A/R
5	AN960C416	Washer, Flat, 1/4 – SST	A/R
6	58-50013-03	Washer, Mylar, 1/4 ID X 1/2 OD	24
7	69NT40-898-1	Panel, Access – Includes:	1
7	69NT40-898-4	Panel, Access <b>69NT40-454, -1, -2, -3</b> – Includes:	1
8	42-01081	Gasket	1
9	69NT20-1033	Bracket, Motor Mount ( <b>69NT20</b> )	2
9	69NT35-1173	Bracket, Motor Mount ( <b>69NT40</b> )	2
10	34-00933-12	Capscrew, Hex Head, 5/16-18 x 1-1/2 lg – SST (NSI)	4
11	34-01181-01	Washer, Flat, 5/16 – SST (NSI)	8
12	34-00667-12	Locknut, 5/16-18 – SST (NSI)	4
13	54-00513-00	Motor, Evaporator Fan ( <b>Two-Speed</b> ) – Includes:	2
14	34-00672	Key, 3/16 x 3/16 x 1-1/4 lg – SST	2
NS	22-50071-00	Capacitor	1
13	54-00507-00	Motor, Evaporator Fan ( <b>One-Speed</b> ) – Includes:	2
14	34-00672	Key, 3/16 x 3/16 x 1-1/4 lg – SST	2
NS	22-50072-00	Capacitor	1
15	38-00121-00SV	Fan, Evaporator (EFM-1) ( <b>69NT20</b> ) – Includes:	1
15	38-00126	Fan, Evaporator (EFM-1) ( <b>69NT40</b> ) – Includes:	1
NS	PL	Setscrews, 5/16-24 x 5/8 lg – SST	2
15	38-00122	Fan, Evaporator (EFM-2) ( <b>69NT20</b> ) – Includes:	1
15	38-00125	Fan, Evaporator (EFM-2) ( <b>69NT40</b> ) – Includes:	1
NS	PL	Setscrews, 5/16-24 x 5/8 lg – SST	2
16	66U1-5361-7	Bolt, Hex Head, 3/8-16 x 1.00 lg – SST (NSI)	8
17	66U1-5321-5	Washer, Flat, 3/8 – SST (NSI)	8
18	AU11JR241	Washer, Lock, 3/8 – SST	8

3.11 EVAPORATOR COIL SECTION -- REAR PANELS REMOVED

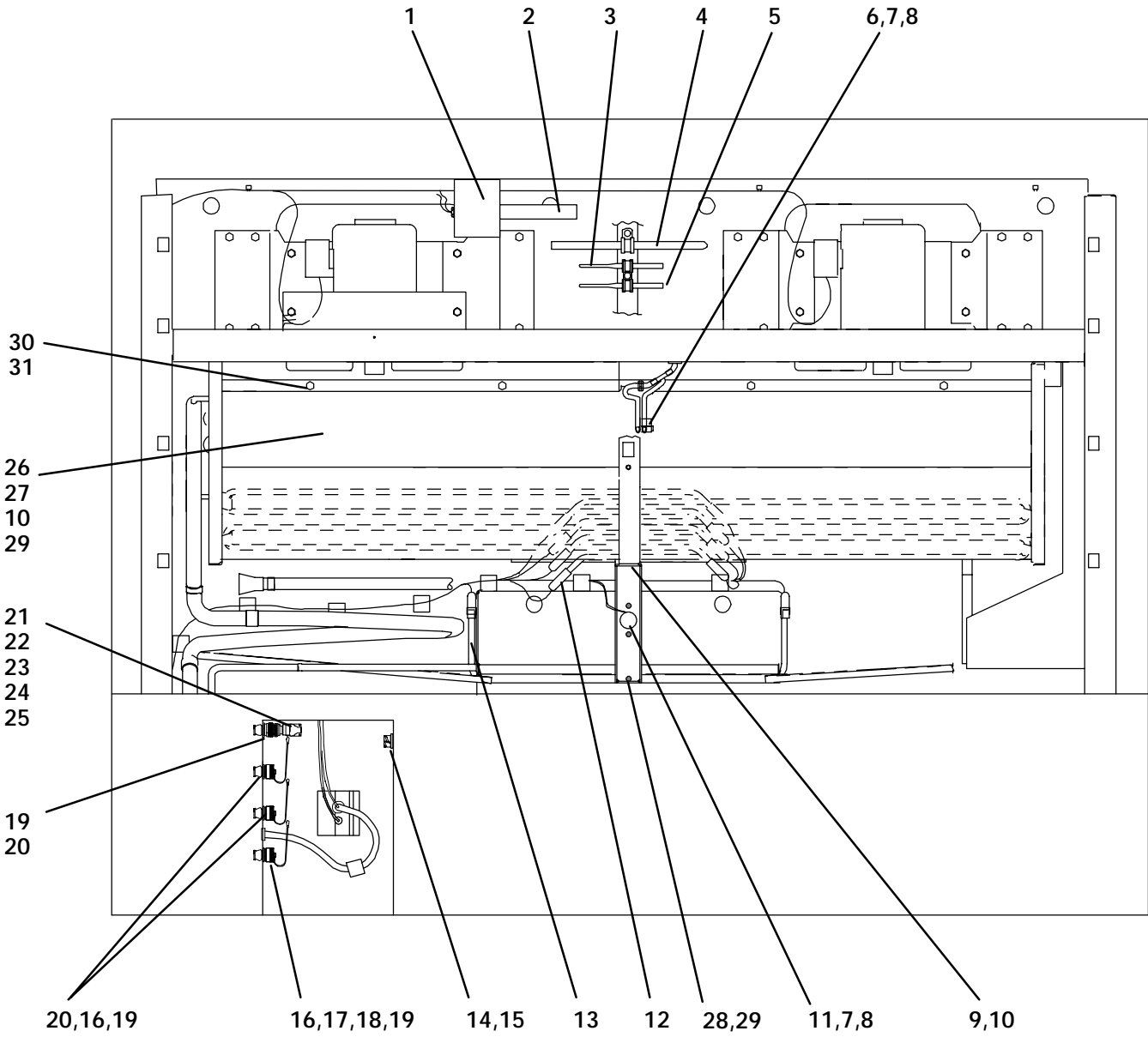



ITEM	PART NO.	DESCRIPTION	QTY
<b>3.11 EVAPORATOR COIL SECTION -- REAR PANELS REMOVED</b>			
1	69NT20-553	Shield Assembly, Rain – Humidistat (NSI) – Optional	1
2	12-01066	Humidistat (HCS) – Optional	1
3	–	Sensor Assembly – Refer to Section 6	–
4	–	Sensor, Thermistor – Refer to Section 3.13	–
5	–	Sensor Assembly – Refer to Section 6	–
6	66U1-6912-8	Thermostat, Defrost (DTT), 75_F (24_C)	1
6	66U1-6912-13	Thermostat, Defrost (DTT), 75_F (24_C) <b>69NT40-454, -2, -3</b>	1
7	PL	Capscrew, Hex Head, #8-32 x 1/2 lg – SST	4
8	PL	Washer, Lock, #8 – SST	4
9	PL	Capscrew, Hex Head, 1/4-20 x 1/2 lg	1
10	PL	Washer, Lock, 1/4 – SST	9
11	66U1-6912-7	Thermostat, High Temperature (HTT), 130_F (54_C)	1
12	66U1-2683-4	Heater	4
13	24-00003	Heater, Drain Pan	1
14	22-02399-00	Dummy Receptacle	1
15	66U1-6835	Gasket	1
16	22-02413-00	Cap and Chain	3
17	22-02412-00	Receptacle Interrogator (ICR)	1
18	58-01256-00	Plug	1
*19	22-02398-02	Socket, Contact ( <b>Silver Plated</b> )	A/R
*19	22-02398-03	Socket, Contact ( <b>Gold Plated</b> )	A/R
20	22-02398-01	Receptacle (PR1, PR2, PR3)	1
–	69NT40-347-1	Sensor Assembly (NSI) – Includes:	–
21	22-02397-00	Connector Assembly (90_) – Includes:	1
22	NSS	Plug	1
23	NSS	Clamp, Cable	1
24	NSS	Bushing	4
*25	22-02397-04	Pin ( <b>Gold Plated</b> )	4
26	69NT21-234-1	Coil, Evaporator ( <b>69NT20</b> ) Does not include thermostats or heaters	1
26	69NT42-968-1	Coil, Evaporator ( <b>69NT40</b> ) Does not include thermostats or heaters	1
26	69NT42-968-5	Coil, Evaporator <b>69NT40-444-15</b> Does not include thermostats or heaters	1
NS	69NT35-6522	Retainer (For Heaters) ( <b>69NT40</b> )	1
NS	69NT20-2032	Retainer (For Heaters) ( <b>69NT20</b> )	1
NS	69NT35-6532	Clip (For Heaters)	4
27	PL	Capscrew, Hex Head, 1/4-20 x 3/4 lg – SST	9
28	PL	Screw, Lag, 1/4 x 2 lg	1
29	PL	Washer, Flat, 1/4	A/R
NS	58-00616-00	Plug, Hole (2 inch diameter) (Located on Fan Deck)	1
30	PL	Capscrew, Hex Head, 1/4-20 x 1-1/4 lg – SST	4
31	69NT35-2692-1	Washer, Fender 1/16 Thk – SST (NSI)	4
* NOTE: Do not mix silver with gold pins and sockets.			

ITEM	PART NO.	DESCRIPTION	QTY
------	----------	-------------	-----

3.12 EVAPORATOR COIL SECTION -- REAR PANELS ATTACHED

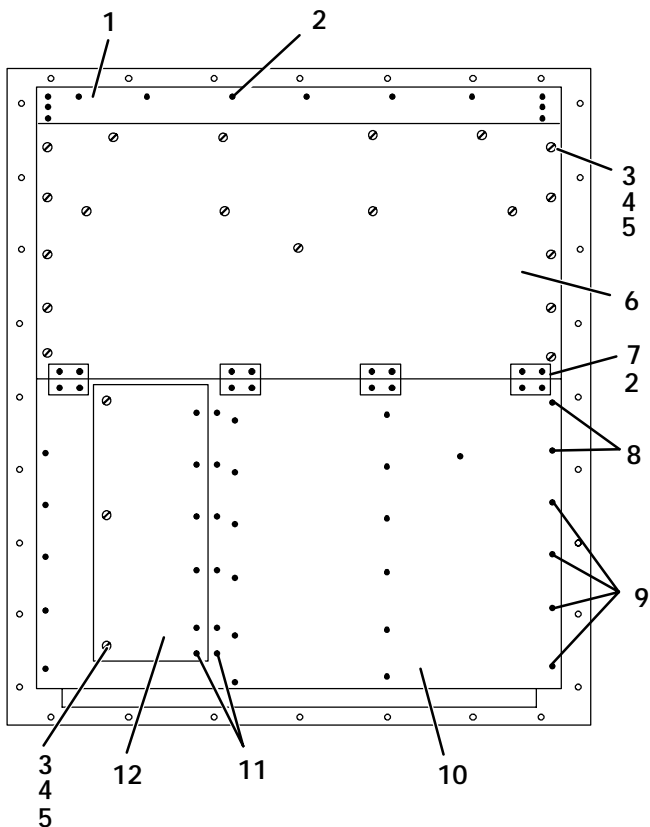

MODELS -- 69NT40-444-4, -6, -15

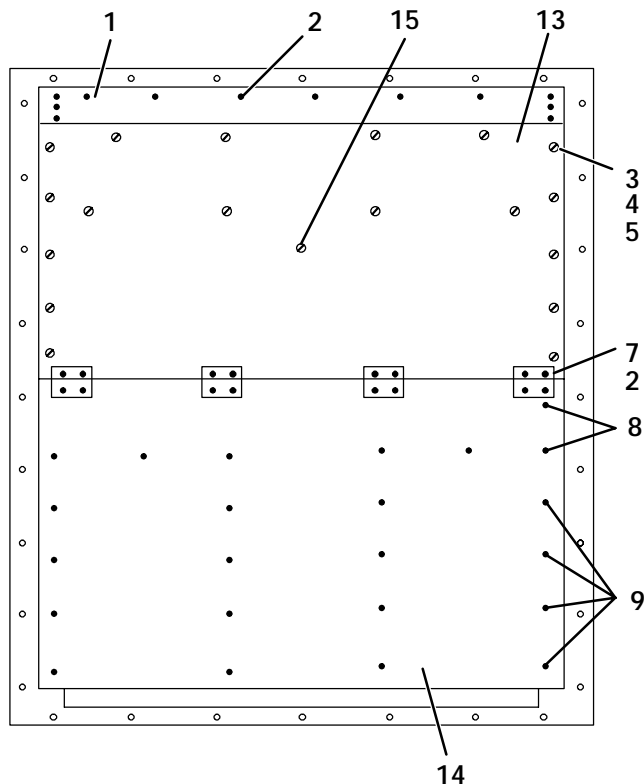

MODEL -- 69NT20-274-1

UNITS WITH HINGED PANELS

1	69NT20-218	Grille, Top (69NT20)	1
1	69NT40-614	Grille, Top (69NT40)	1
2	66U1-6832-1	Rivet, Blind, 5/16 Diameter, Grip Range – 1/8-1/4 (NSI)	13
3	34-01150-04	Stud, 1/4 Turn	15
4	34-01150-30	Washer, Retaining	15
5	34-01150-31	Receptacle, Retaining	15
6	69NT40-634	Panel, Upper – Includes:	1
NS	NSS	Drain Pan, Center	1
NS	NSS	Drain Pan, Side	2
7	69NT35-3282	Hinge	4
8	66U1-6832-6	Rivet, Blind, 1/4 Diameter, Grip Range – 1/8-3/16 (NSI)	A/R
9	66U1-6832-3	Rivet, Blind, 1/4 Diameter, Grip Range – 3/16-1/4 (NSI)	8
10	69NT35-6744	Panel, Bottom	1
11	34-00928-04	Rivet, Blind, 1/8 Diameter, Grip Range – 1/4-5/16 (NSI)	10
12	69NT40-567	Door, Access – Includes:	1
NS	66U1-2803-8	Hinge	1
3	34-01150-04	Stud, 1/4 Turn	3
4	34-01150-30	Washer, Retaining	3
13	69NT40-578-1	Panel, Upper – SST – Includes:	1
NS	NSS	Drain Pan	1
14	69NT35-3494	Panel, Bottom – SST	1
NS	66U1-8075-F25	Gasket (25 ft, Cut to length)	A/R
15	34-01150-06	Stud, 1/4 Turn, 1.03 lg	1

ITEM	PART NO.	DESCRIPTION	QTY
------	----------	-------------	-----

3.12 EVAPORATOR COIL SECTION -- REAR PANELS ATTACHED (CONTINUED)

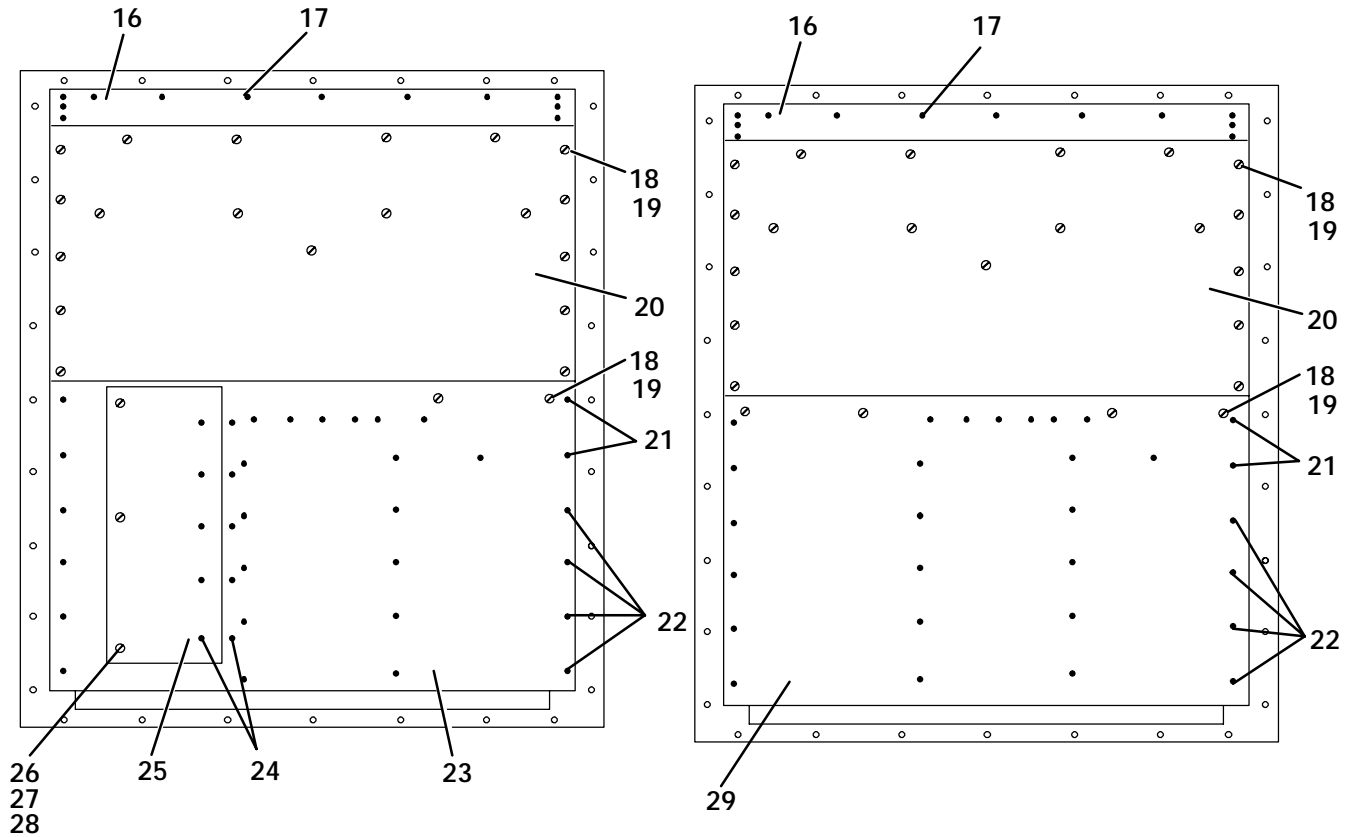

MODELS -- 69NT20-274  
69NT40-444, -1, -2, -9, -11, -12, -13, -14, -16

MODELS -- 69NT20-274-2  
69NT40-444-3, -7, -8, -17  
69NT40-454, -2

UNITS WITH BOLTED PANELS

16	69NT20-218	Grille, Top ( <b>69NT20</b> )	1
16	69NT40-614	Grille, Top ( <b>69NT40</b> )	1
17	66U1-6832-1	Rivet, Blind, 5/16 Diameter, Grip Range – 1/8-1/4 (NSI)	13
18	66U1-2403	Screw, Machine, Truss Head, #10-24 x 1/2 lg – SST (NSI)	19
19	69NT35-2692	Washer, Fender, #10 x 1.00 OD – SST (NSI)	19
20	69NT40-624-1	Panel, Upper – Includes:	1
NS	NSS	Drain Pan, Side	2
NS	NSS	Drain Pan, Center	1
21	66U1-6832-6	Rivet, Blind, 5/16 Diameter, Grip Range – 1/8-3/16 (NSI)	A/R
22	66U1-6832-3	Rivet, Blind, 5/16 Diameter, Grip Range – 3/16-1/4 (NSI)	8
23	69NT35-6744	Panel	1
24	34-00928-04	Rivet, Blind, 1/8 Diameter, Grip Range – 1/4-5/16 (NSI)	10
25	69NT40-567	Door, Access – Includes:	1
NS	66U1-2803-8	Hinge	1
26	34-01150-04	Stud, 1/4 Turn	3
27	34-01150-30	Washer, Retaining	3
28	34-01150-31	Receptacle, Retaining	2
29	69NT35-3014	Panel, Lower Back	13
NS	66U1-8075-F25	Gasket (25 ft, Cut to length)	A/R

ITEM	PART NO.	DESCRIPTION	QTY
------	----------	-------------	-----

3.12 EVAPORATOR COIL SECTION -- REAR PANELS ATTACHED (CONTINUED)

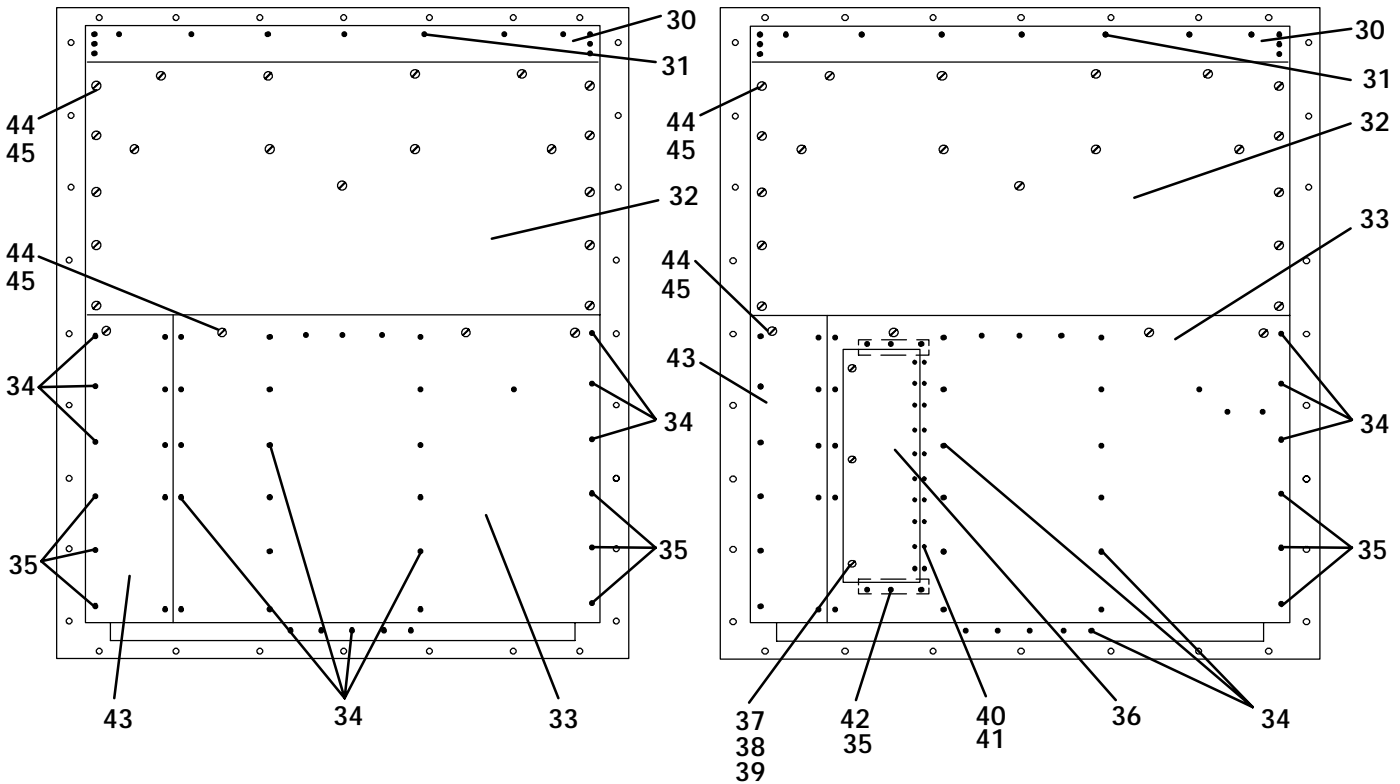

MODELS -- 69NT20-274-3  
69NT40-454-1, -3

MODELS -- 69NT40-444-10, -18, -19, -20, -21, -22, -23  
& 69NT40-441-21, -22, -23, -24, -25

UNITS WITH BOLTED PANELS

30	69NT20-218	Grille, Top (NT20)	1
30	69NT40-614	Grille, Top (NT40)	1
31	66U1-6832-1	Rivet, Blind, 5/16 Diameter, Grip Range – 1/8-1/4 (NSI)	A/R
	69NT40-624-1	Panel Assembly, Upper – Includes:	1
NS	NSS	Drain Pan, Side	2
NS	NSS	Drain Pan, Center	1
33	69NT35-9744	Panel, Bottom	1
33	69NT35-9744-3	Panel, Bottom 69NT20-274-3 & 69NT40-454-1,-3	1
34	66U1-6832-6	Rivet, Blind, 1/4 Diameter, Grip Range – 1/8-3/16 (NSI)	A/R
35	66U1-6832-3	Rivet, Blind, 1/4 Diameter, Grip Range – 3/16-1/4 (NSI)	A/R
36	69NT40-567	Door, Access – Includes:	1
NS	66U1-2803-8	Hinge	1
37	34-01150-04	Stud, 1/4 Turn	3
38	34-01150-30	Washer, Lock	3
39	34-01150-31	Receptacle, Retaining	3
40	34-00928-04	Rivet, Blind, 1/8 Diameter, Grip Range – 1/4-5/16 – SST (NSI)	20
41	69NT35-3772-3	Spacer, Hinge (NSI)	2
42	69NT35-6692	Plate (NSI)	1
43	69NT35-9744-2	Panel, Bottom, Side (Provision for heat exchanger)	1
44	66U1-2403	Screw, Machine, Truss Head, #10-24 x 1/2 lg – SST (NSI)	19
45	69NT35-2692	Washer, Fender, #10 x 1.00 OD – SST (NSI)	19
NS	66U1-8075-F25	Gasket (25 ft, Cut to length)	A/R

ITEM	PART NO.	DESCRIPTION	QTY
------	----------	-------------	-----

3.13 RECORDING THERMOMETER (PARTLOW)

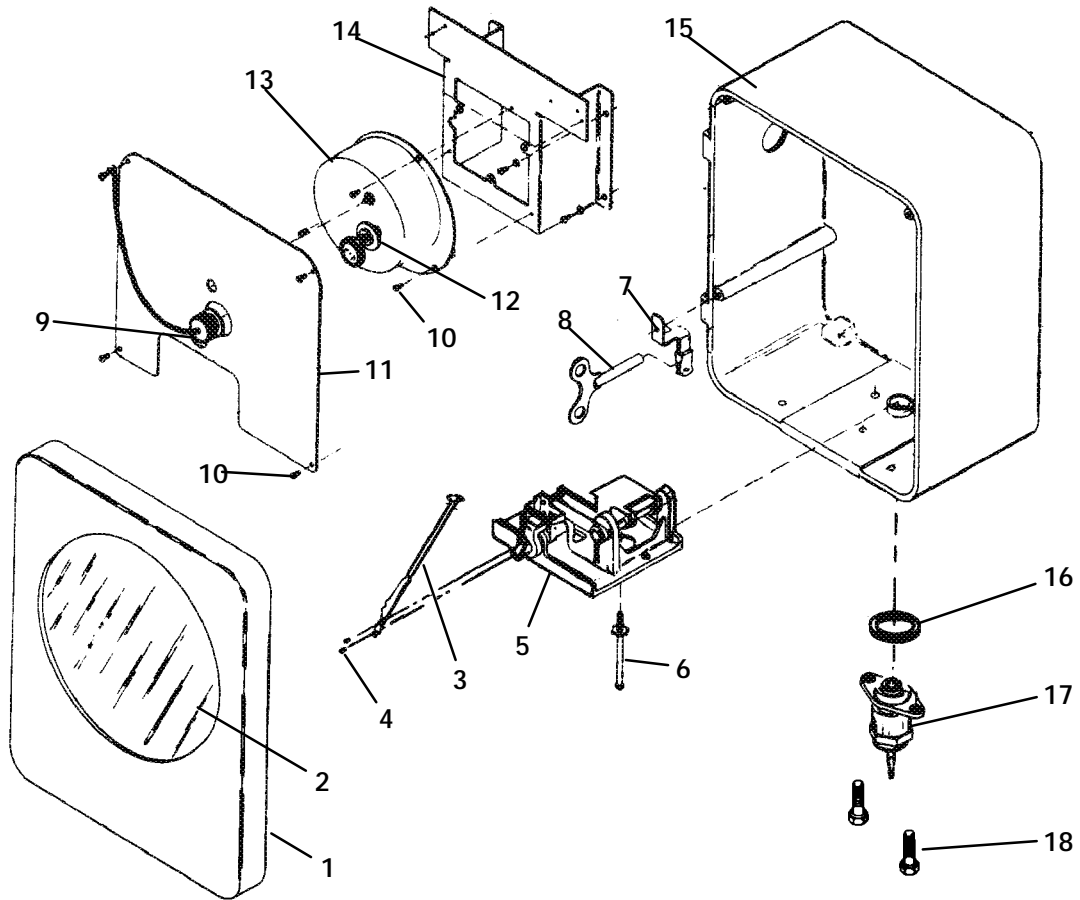

-	12-01076-00	Recording Thermometer – Includes:	1
1	09-00265-00	Cover Assembly (Bottom Latch) – Includes:	1
NS	09-00100-01	Seal, Cover – Rubber	1
NS	09-00100-02	Gasket, Cover Glass	1
2	09-00101	Glass, Cover	1
NS	09-00102	Catch Assembly, Cover	2
3	09-00104-05	Kit, Stylus – Includes:	1
4	NSS	Screw, Round Head, #2-56 x 3/16 lg	2
5	09-00147	Mechanism Assembly	1
6	09-00112	Rod, Push (Includes Setscrews)	1
7	09-00115	Clip, Key Mounting	1
8	09-00114	Key, Clock Winding	1
9	09-00119	Nut and Chain, Chart ( <b>Sonceboz Clock</b> )	1
9	09-00180-00	Nut and Chain, Chart ( <b>Gluck Clock</b> )	1
10	PL	Screw, Round Head #6-32 x 5/16	7
11	09-00116	Platen, Chart	1
12	09-00118	Flange, Chart Drive ( <b>Sonceboz</b> )	1
12	09-00180-01	Flange, Chart Drive ( <b>Gluck</b> )	1
13	09-00123	Clock, 31 Day, CCW (Counterclockwise)	1
14	09-00132	Stand, Mounting, Chart Drive (NSI)	1
15	09-00267-00	Case (Top Hinge)	1
16	09-00137	O-Ring, Element Flange	4
17	09-00209	Element, 9 ft lg – Includes:	1
NS	09-00222	Sensor, Thermistor (Accessory 344 and Jack) – 15 ft lg	1
NS	22-02243	Pin (Use with Partlow Thermistor Assembly)	3
18	09-00136	Screw, Flange (NSI)	2
NS	09-00128	Charts _F – 31 Day (Box of 50) (-20_F to +80_F)	A/R
NS	09-00128-01	Charts _C – 31 Day (Box of 50) (-25_C to +25_C)	A/R

3.14 RECORDING THERMOMETER (SAGINOMIYA)

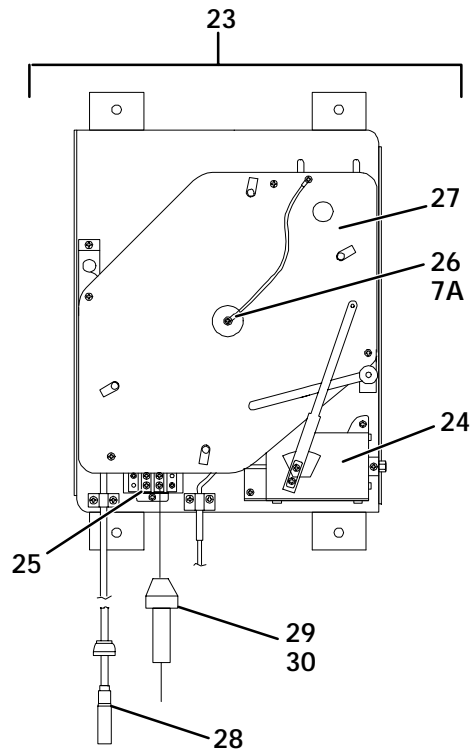
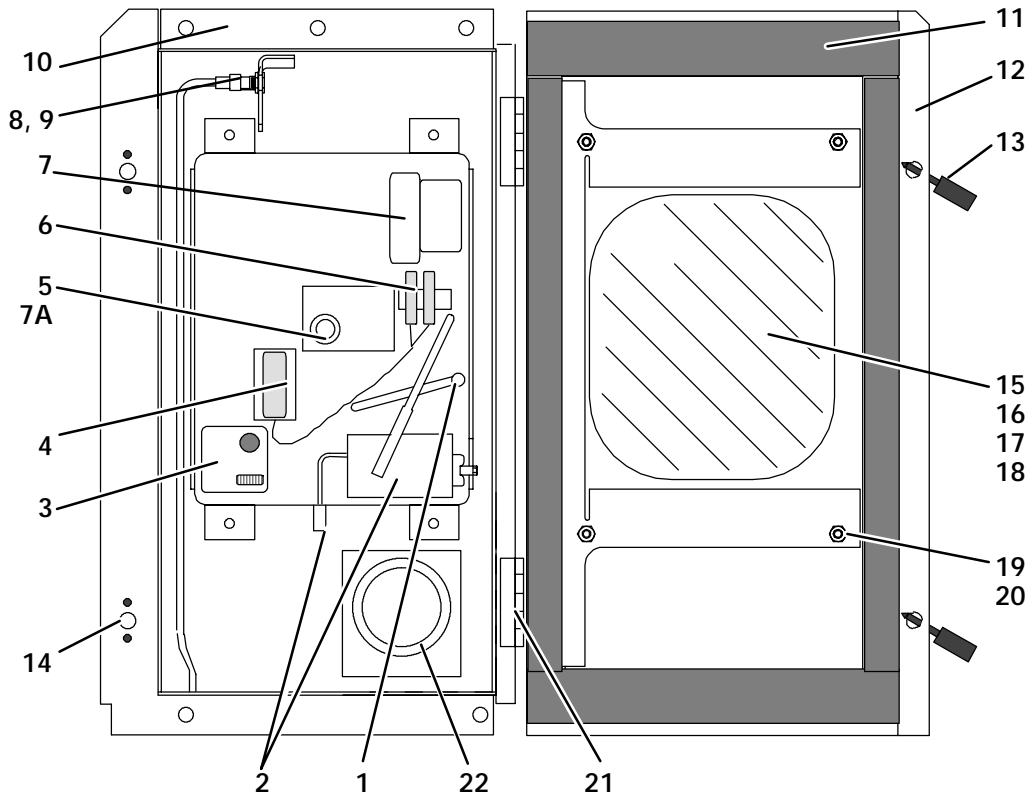

ITEM	PART NO.	DESCRIPTION	QTY
<b>3.14 RECORDING THERMOMETER (SAGINOMIYA)</b>			
–	12-01094-00	Recording Thermometer – Includes:	1
1	09-00324-00	Stylus, Left Arm	1
2	09-00320-00	Element Assembly (9 ft.) (2.74 M)	1
3	09-00321-00	Indicator, Voltage	1
4	PL	Battery (Mallory R14P/S 1.5 vdc)	1
5	09-00326-00	Shaft, Chart	1
6	09-00329-00	Block, Terminal (NSI)	1
7	09-00322-00	Timer (31 Day)	1
NS	09-00323-00	Plate, Recorder	1
7A	09-00325-00	Nut, Chart (Male)	1
8	69NT40-402-1	Sensor Assembly, Return Temperature (Optional) – Includes:	1
NS	12-01095-00	Sensor, Thermistor	1
9	22-02370-00	Jack, Phono (Optional)	2
10	69NT41-754-1	Box Assembly, Recorder (NSI)	1
11	42-01098-00	Gasket, Door	1
12	69NT41-844	Door Assembly, Recorder Box	1
13	66U1-6811-10	Screw, Retaining	2
NS	34-01226-00	Washer, Retaining	2
14	34-01142-01	Receptacle, Retaining	2
15	PL	Window, Lexan (8.37 x 10 x .12 inches thick) (212 x 254 x 3 mm)	1
16	PL	Gasket, Window	1
17	69NT35-9343	Bracket, Window Mounting (NSI)	1
18	69NT35-5492	Plate, Window Mounting	2
19	PL	Nut, Hex Head, #10-32 – SST	4
20	PL	Washer, Lock, #10 – SST	4
21	69NT40-392	Hinge Assembly	2
22	66U1-3823-1	Meter, Hour (Resettable) – Optional	1
23	12-00281-00	Recording Thermometer <b>69NT40-444-8</b> – Includes:	1
24	09-00338-00	Element Assembly	1
25	09-00339-00	Box, Battery	1
26	09-00340-00	Timer	1
27	09-00341-00	Plate, Recorder	1
NS	09-00342-00	Board, Circuit	1
28	09-00343-00	Sensor, Thermistor	1
29	22-02387-00	Holder, Fuse In-Line <b>69NT40-444-8</b>	1
30	HY10FJ203	Fuse, 3 Amp <b>69NT40-444-8</b>	1
NS	09-00128-01	Charts _C – 31 Day (Box of 50) (–25_C to +25_C)	A/R
NS	09-00128	Charts _F – 31 Day (Box of 50) (–20_F to +80_F)	A/R

ITEM	PART NO.	DESCRIPTION	QTY
------	----------	-------------	-----

3.15 THERMOSTATIC EXPANSION VALVE -- Alco

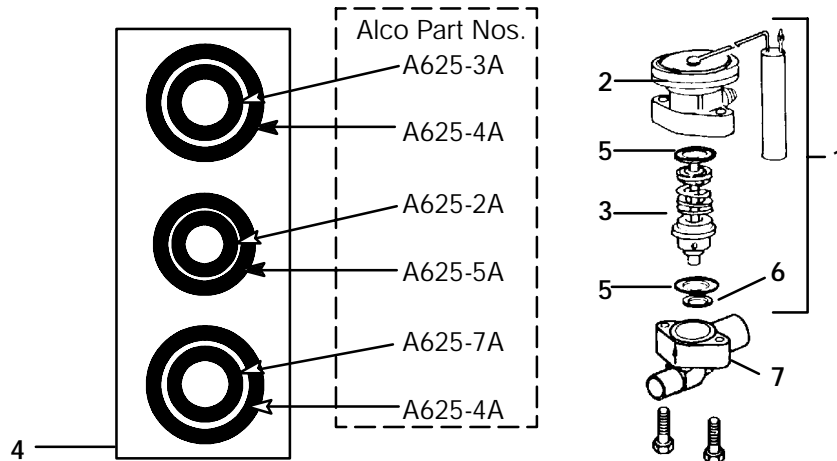

1	14-01104-02	Kit, Repair ( <b>69NT20</b> ) – Includes:	1
1	14-01104-03	Kit, Repair ( <b>69NT40</b> ) – Includes:	1
2	NSS	Power Head Assembly and Gasket, Item 5	1
3	NSS	Cage Assembly and Gasket, Item 6	1
4	66U1-6225	Gasket Set, Universal – Includes:	1
5	NSS	Gasket, Body Flange A625-4A	2
6	NSS	Gasket, Seat – A625-2A	1
7	66U1-1214-13	Flange, Body (NSI)	1

3.16 SUCTION SOLENOID VALVE (69NT40 ONLY)

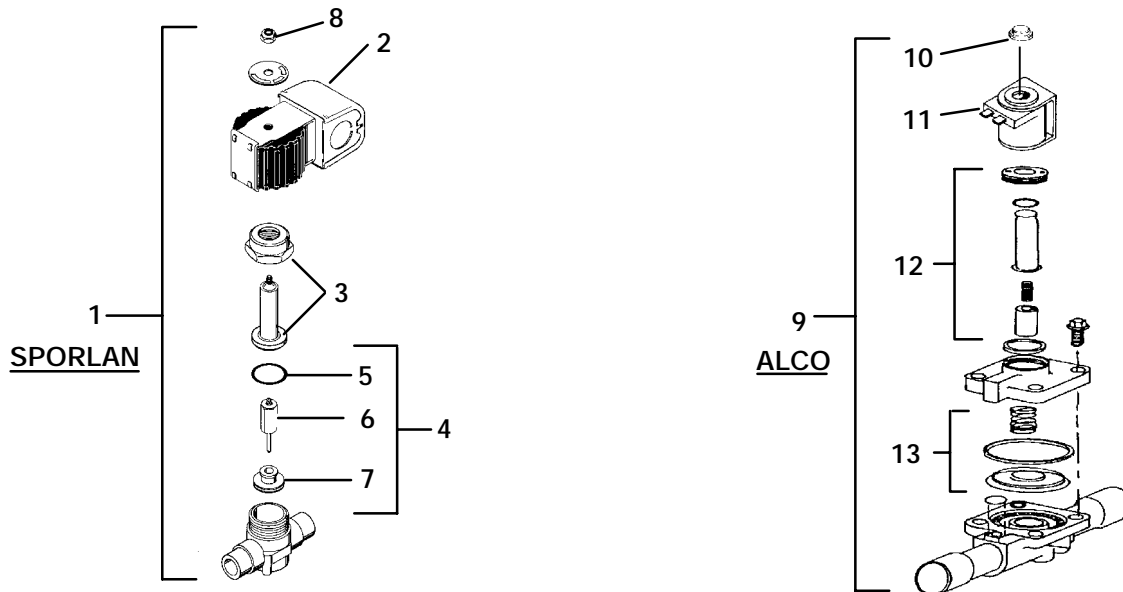

1	14-01083	Solenoid Valve, Suction – Includes:	1
2	14-50010	Coil	1
3	NSS	Tube, Enclosing	1
4	14-50011	Kit, Repair – Includes:	1
5	NSS	Gasket	1
6	NSS	Stem and Plunger Assembly	1
7	NSS	Disc, Seat	1
8	34-50012-00	Screw (Special), Coil Hold Down	1
9	14-00192-00	Solenoid Valve, Suction – Includes:	1
10	17-40408-02	Cap, Snap	1
11	14-50027-00	Coil	1
12	14-50025-00	Kit, Repair	1
13	14-50026-00	Kit, Repair Diaphragm	1



ITEM	PART NO.	DESCRIPTION	QTY
------	----------	-------------	-----

3.17 MODULATING SOLENOID VALVE

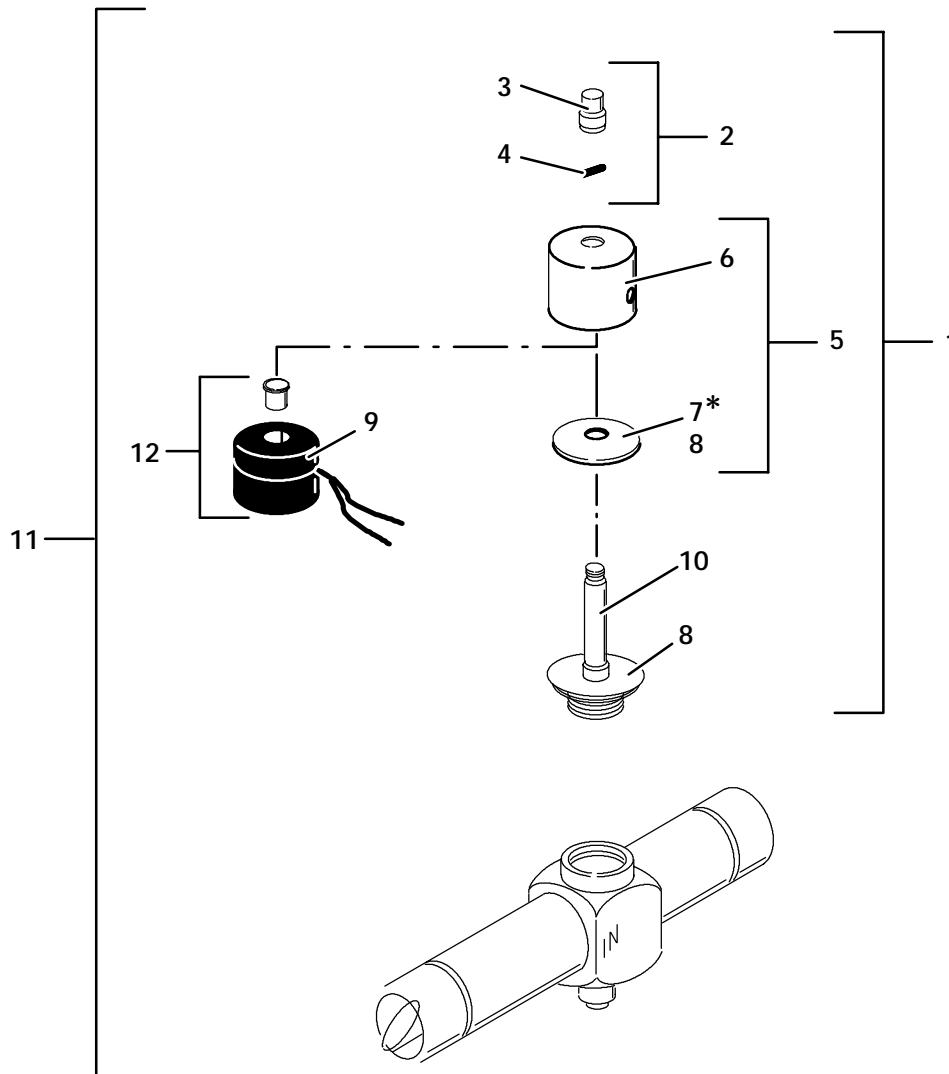

1	14-50021-01	Kit, Enclosing Tube & Coil Housing – Includes:	1
2	14-50021-03	Nut, Coil – Includes:	1
3	NSS	Nut, Coil	1
4	NSS	O-Ring, Coil Nut	1
5	14-50021-04	Housing, Coil – Includes:	1
6	NSS	Housing, Coil	1
*7	NSS	Plate, Coil Bottom	1
8	NSS	O-Ring, Coil Bottom Plate	1
9	NSS	Sleeve, Solenoid Coil	1
10	NSS	Tube Assembly, Coil Plate & Enclosing	1
11	14-01100-01	Valve, Modulating Solenoid – Includes:	1
12	14-50021-02	Coil, Solenoid – Includes:	1
9	NSS	Sleeve, Solenoid Coil	1

\* NOTE: Coil bottom plate is only supplied in Kit 14-50021-04 as a separate item for use on early style enclosing tube assemblies.

ITEM	PART NO.	DESCRIPTION	QTY
------	----------	-------------	-----

### 3.18 COMPRESSOR MOUNTING AND GAUGES

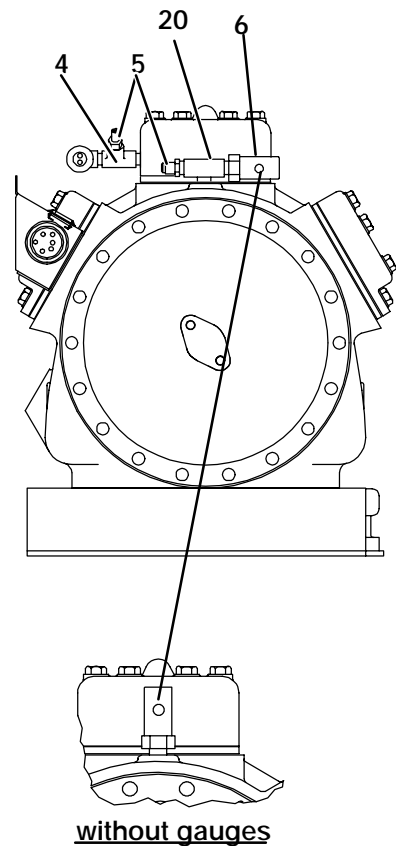
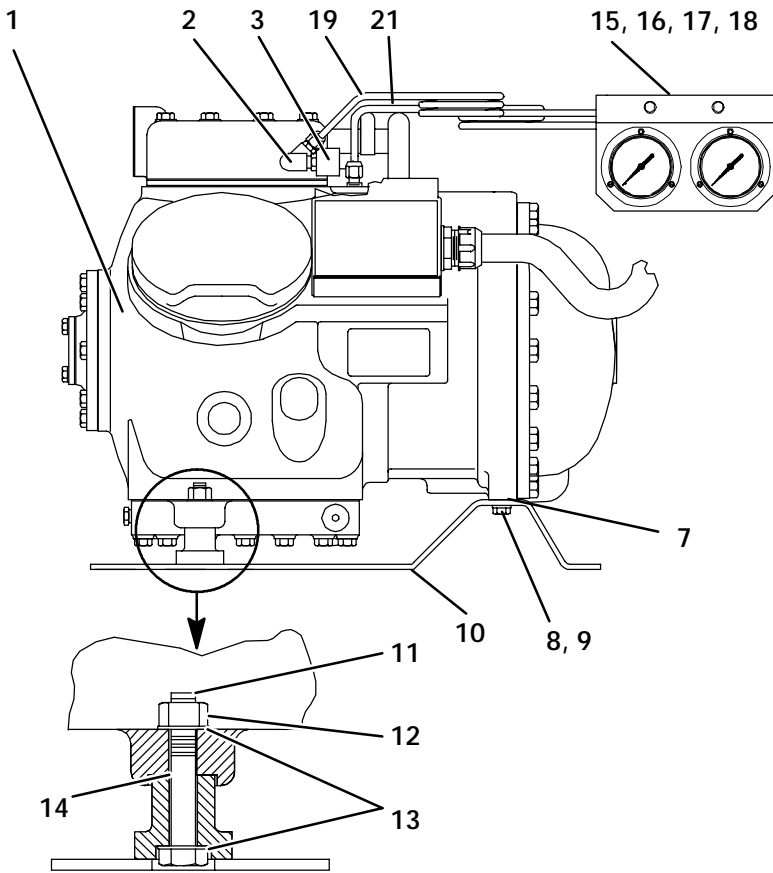

1	-	Compressor – Refer to Section 5	-
2	14-01093-00	Snubber Assembly	1
3	66U1-6942-4	Switch, High Pressure	1
3	66U1-6942-6	Switch, High Pressure <b>69NT40-444-18, -19, -22, -23 &amp; 69NT40-441-21, -22, -23, -25</b>	1
4	CA21JA051	Tee, 1/4 npt (NSI)	1
5	06DA403-844	Valve Assembly, Core, Check – Brass	2
6	14-00195-02	Valve, Low Side Pressure Relief <b>Used on Unit with Provision for R-22</b>	1
7	69NT35-6132	Protector (Compressor to Compressor Base)	1
8	PL	Washer, Lock, 3/8 – SST	2
9	PL	Capscrew, Hex Head, 3/8-16 x 1-1/4 lg – SST	2
10	69NT43-108	Base, Compressor	1
NS	PL	Bolt, Hex Head, 3/8-16 x 1.00 lg – SST	7
NS	PL	Washer, Flat, 3/8 – SST	7
NS	PL	Washer, Lock, 3/8 – SST	7
NS	58-50013-00	Washer, Mylar, 1/2 ID x 1.00 OD	7
11	PL	Capscrew, 7/16-14 x 2-3/4 lg – SST	2
12	PL	Locknut, 7/16-14 – SST	2
13	PL	Washer, Flat, 7/16 – SST	4
14	58-50013-01	Washer, Mylar, 1/2 ID x 1-1/8 OD	2
15	69NT40-942	Stiffener Assembly	1
NS	PL	Screw, Hex Head, #10-24 x 3/4 lg – SST	2
NS	PL	Washer, Flat, #10 – SST	2
16	69NT40-912	Bracket Assembly, Gauge – Optional (NSI)	1
17	12-01124-01	Gauge, Suction Pressure – Optional	1
18	12-01125-01	Gauge, Discharge Pressure – Optional	1
19	69NT41-543	Tube Assembly, High Pressure	1
20	40-00249-01	Tee, Male, 1/4 fpt x 1/4 fpt x 1/4 mpt – Brass (NSI)	1
21	69NT41-553	Tube Assembly, Low Pressure	1

ITEM	PART NO.	DESCRIPTION	QTY
------	----------	-------------	-----

3.19 MAKEUP AIR COVER OPTION

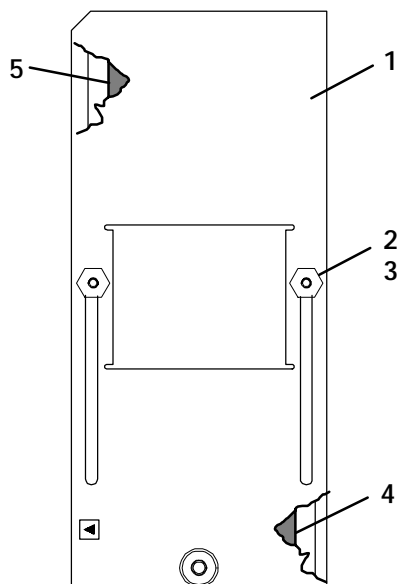

**69NT40-976**

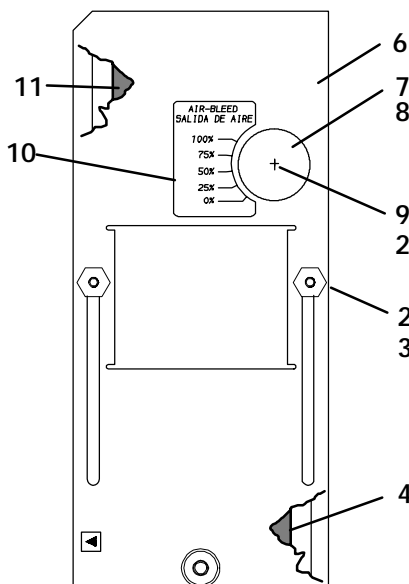

**69NT40-976-1**

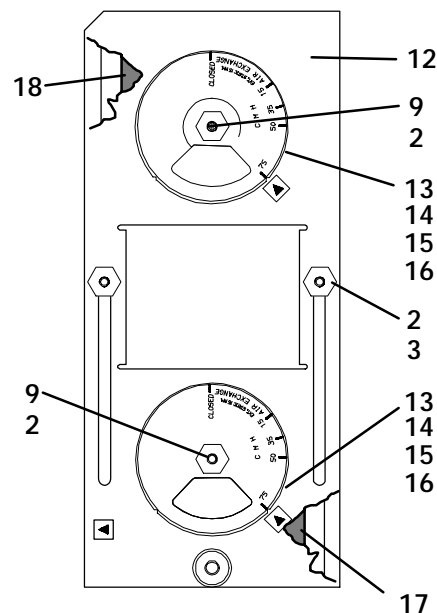

**69NT40-976-2**

1	69NT40-976	Cover, Makeup Air – Includes:	1
2	PL	Washer, Flat, 1/4 – SST	1
3	PL	Nut, Hex, 1/4-20 UNC-2B – SST	1
4	69NT35-2322-5	Gasket, Cover (NSI)	1
5	69NT35-2322-10	Gasket, Cover (NSI)	1
6	69NT40-976-1	Cover, Makeup Air <b>69NT40-454, -2, -3</b> – Includes:	1
7	69NT40-976-4	Cover Assembly, Air Bleed – Includes:	1
8	42-00203-00	Gasket	1
2	PL	Washer, Flat, 1/4 – SST	1
4	69NT35-2322-5	Gasket, Cover (NSI)	1
9	66U1-5362-1	Nut, Wing, 1/4-20 – SST	1
10	69NT35-9483	Label, Air Bleed (NSI)	1
11	69NT35-2322-11	Gasket, Cover (NSI)	1
12	69NT40-976-2	Cover, Makeup Air <b>(With Air Bleed)</b> – Includes:	1
13	69NT40-976-3	Cover Assembly, Air Bleed – Includes:	2
14	42-00233-00	Gasket, Air Exchange (NSI)	2
15	69NT35-1417	Label, Air Bleed (NSI)	2
2	PL	Washer, Flat, 1/4 – SST	2
9	66U1-5362-1	Nut, Wing, 1/4-20 – SST	2
16	34-06053-00	Washer, Mylar	2
17	69NT35-6932-1	Gasket, Cover (NSI)	1
18	69NT35-6932	Gasket, Cover (NSI)	1

3.20 VOLTAGE OPTIONS

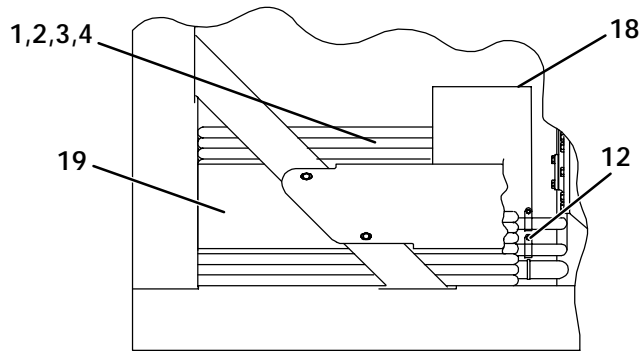

ALL OTHER MODELS

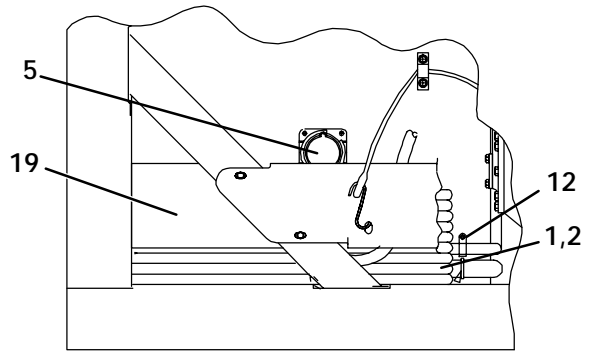

69NT40-454

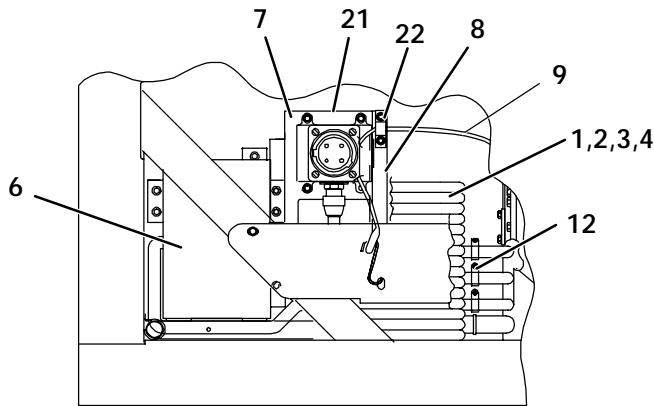

69NT40-444-3, -7, -8

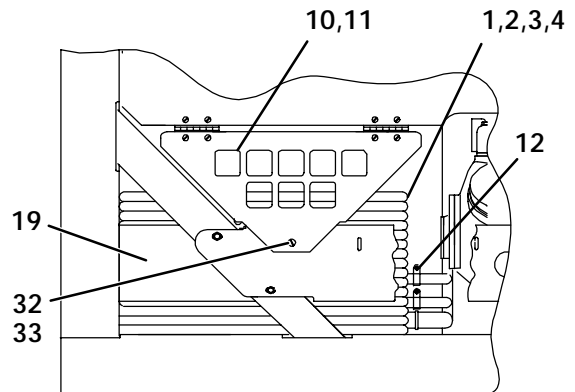

69NT40-444-6

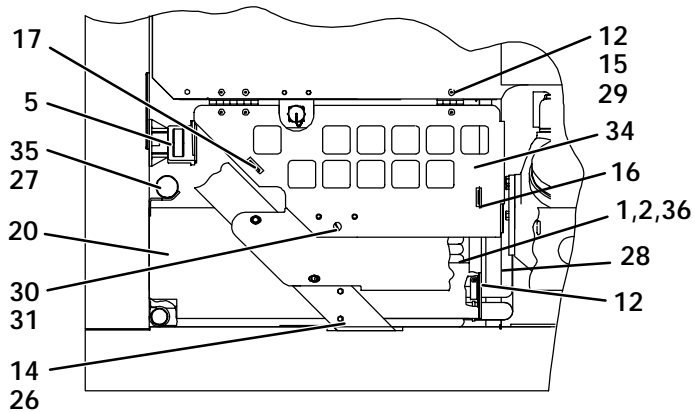

69NT40-454-2, -3

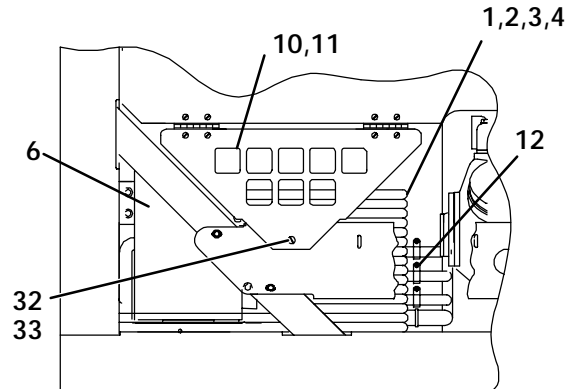

69NT40-444-15, -17

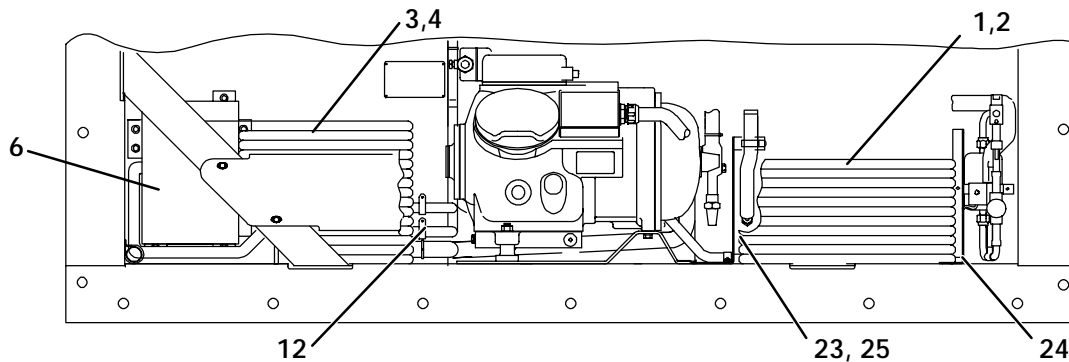

69NT20-274-1

ITEM	PART NO.	DESCRIPTION	QTY
<b>3.20 VOLTAGE OPTIONS</b>			
1	22-01551-00	Cable, Power ( <b>460 vac</b> ) (NSI)	A/R
2	22-02378-00	Plug, Power ( <b>460 vac</b> ) <b>Mennekes</b>	1
NS	22-02324-01	Bushing (For P/N 22-02378-00 & 22-02232-00) (NSI)	4
2	66U1-2443	Plug, Power ( <b>460 vac</b> ) – <b>69NT40-444-4, -6, -15</b>	1
2	22-01571-00	Plug, Power ( <b>460 vac</b> ) – <b>69NT40-454, -2, -3</b> (NSI)	1
2	22-02232	Plug, Power ( <b>460 vac</b> ) – <b>69NT40-454-1</b>	1
3	66U1-9782-1	Cable, Power ( <b>230 vac</b> ) (NSI)	A/R
4	22-02322-00	Plug, Power ( <b>230 vac</b> ) (NSI)	1
4	66U1-6782-3	Plug, Power ( <b>230 vac</b> ) <b>69NT40-444-7, -8</b> (NSI)	1
5	22-01561-01	Receptacle (for power plug) – <b>69NT40-454, -2, -3</b>	1
6	76-00365-01	Transformer, Power (Optional)	1
7	22-02344	Receptacle, Power (460 vac) (NSI) – <b>69NT40-444-3, -7, -8</b>	1
8	69NT35-5992	Strap (NSI)	1
9	66U1-2603	Strap, Hold Down	1
10	69NT41-724-1	Cover, Power Cable	1
11	69NT35-5262	Hinge, Cover	2
12	34-06053-05	Washer, Mylar	16
13	58-50013-02	Washer, Mylar, 1/4 ID X 13/16 OD	8
14	58-04026-07	Protector, Mylar	1
15	58-04001-00	Protector, Mylar	2
16	58-04026-12	Protector, Mylar	1
17	58-04026-13	Protector, Mylar	1
18	69NT35-9393	Plate – <b>69NT40-444-4</b>	1
19	69NT35-3573	Panel (NSI)	1
20	69NT35-1337	Panel (NSI)	1
21	69NT40-717	Bracket (NSI)	1
22	58-50013-04	Washer, Mylar 1.00 OD X 1/4 ID	A/R
23	69NT20-533	Partition (NSI)	1
24	69NT35-6153	Partition (NSI)	1
25	66U1-8065-F25	Gasket (25 Ft, Cut to length)	A/R
26	58-00989-00	Protector, Mylar	2
27	58-00024-23	Plug, Cap (NSI)	1
28	69NT41-473	Panel	1
29	34-01167-01	Retainer	2
30	34-01150-31	Receptacle	1
31	69NT35-5862	Bracket (NSI)	1
32	34-01150-04	Stud, 1/4 Turn	1
33	34-01150-30	Washer, Retaining	1
34	69NT35-9044	Cover, Power Cable (NSI)	1
35	69RN40-863-1	Holder, Document (NSI)	1
36	22-01617-00	Stop, Cable	1
NS	22-02373-00	Plug, Remote Monitoring (Optional)	1
NS	22-02382-00	Receptacle, Dummy	1

3.21 LABELS AND DECALS

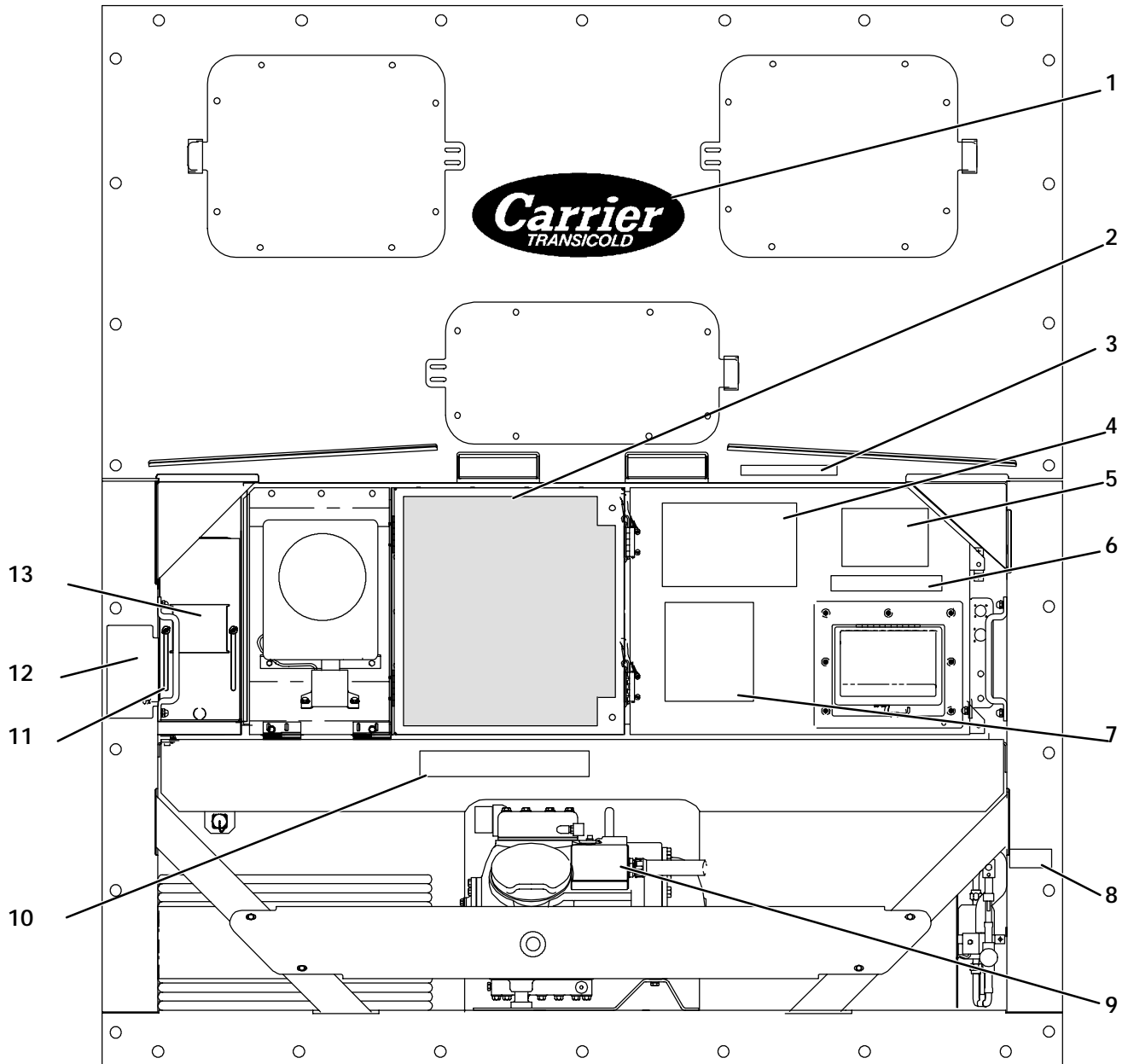

ITEM	PART NO.	DESCRIPTION	QTY
<b>3.21 LABELS AND DECALS</b>			
1	62-02531-00	Decal, Carrier Transicold	1
2	66U1-8912	Label, Direction Arrow	1
3	69NT35-8653	Label, Humidistat (NSI)	1
4	69NT35-8084	Label, Operating (NSI) – 69NT20-274-1	1
4	69NT35-7784	Label, Operating (NSI) – 69NT20-274 & 69NT40-444, -2, -9, -11, -12, -13	1
4	69NT35-7804	Label, Operating (NSI) – 69NT40-444-1, -10, -20, -21, -22, -23 & 69NT40-441-21, -22, -23, -25	1
4	69NT35-8064	Label, Operating (NSI) – 69NT40-444-3, -7	1
4	69NT35-8564	Label, Operating (NSI) – 69NT40-444-8	1
4	69NT35-7924	Label, Operating (NSI) – 69NT40-444-4	1
4	69NT35-7964	Label, Operating (NSI) – 69NT40-454, -2, -3	1
4	69NT35-8454	Label, Operating – 69NT40-454-1	1
4	69NT35-9344	Label, Operating (NSI) – 69NT20-274-2, -3 & 69NT40-441-24, -444-14	1
4	69NT35-9754	Label, Operating (NSI) – 69NT40-444-15, -17	1
4	69NT35-9464	Label, Operating (NSI) – 69NT40-444-16, -18, -19	1
5	69NT35-7794	Label, Fan Warning (NSI)	1
5	69NT35-7974	Label, Fan Warning (NSI) – 69NT40-454, -1, -2, -3	1
5	69NT35-8094	Label, Fan Warning (NSI) – 69NT20-274-1	1
5	69NT35-7934	Label, Fan Warning (NSI) – 69NT40-444-15	1
6	69NT35-8553	Label, Humidity Control Sensor (NSI)	1
7	69NT35-7094	Label, Function Code (NSI)	1
7	69NT35-8164	Label, Function Code (NSI) – 69NT20-274-1	1
7	69NT35-8474	Label, Function Code (NSI) – 69NT40-454-1	1
7	69NT35-8824	Label, Function Code (NSI) – 69NT40-444-10, -17 & 69NT40-441-21, -22, -23, -25	1
8	66U1-7471	Label, Charge with R-12 (NSI)	1
9	69NT35-3842	Label, Compressor-Frost	1
10	69NT35-4773	Label, Warning (NSI)	1
11	66CH1-1002-33	Label, Arrow (NSI)	1
12	69NT35-8413	Label, Air Exchange (NSI) – 69NT20-274, -2, -3 & 69NT40-441-24, -444, -2, -9, -11, -14	1
12	69NT35-5323	Label, Air Exchange (NSI) – 69NT40-444-1, -3, -4, -6, -7, -8, -10, -17, -20, -21, -22, -23 & 69NT40-441-21, -22, -23, -25	1
12	69NT35-9493	Label, Air Exchange – 69NT40-454, -2, -3	1
12	69NT35-9593	Label, Air Exchange (NSI) – 69NT20-274-1	1
12	69NT35-9903	Label, Air Exchange (NSI) – 69NT40-454-1	1
12	69NT35-1287	Label, Air Exchange (NSI) – 69NT40-444-12, -13, -16, -18, -19	1
13	69NT35-7012	Label, Fresh Air (NSI) – 69NT40-444-12, -13, -16	1
13	69NT35-1417	Label, Fresh Air (NSI) – 69NT40-444-18, -19	2
NS	69NT35-8223	Label, USDA (Located on rear side panel)	1
NS	69NT35-6512	Label, Nitrogen Feed (NSI) – 69NT40-454, -2, -3	1
NS	69NT35-9483	Label, Air Bleed (NSI) – 69NT40-454, -2, -3	1

4. ACCESSORIES

4.1 INTERROGATOR AND ACCESSORIES

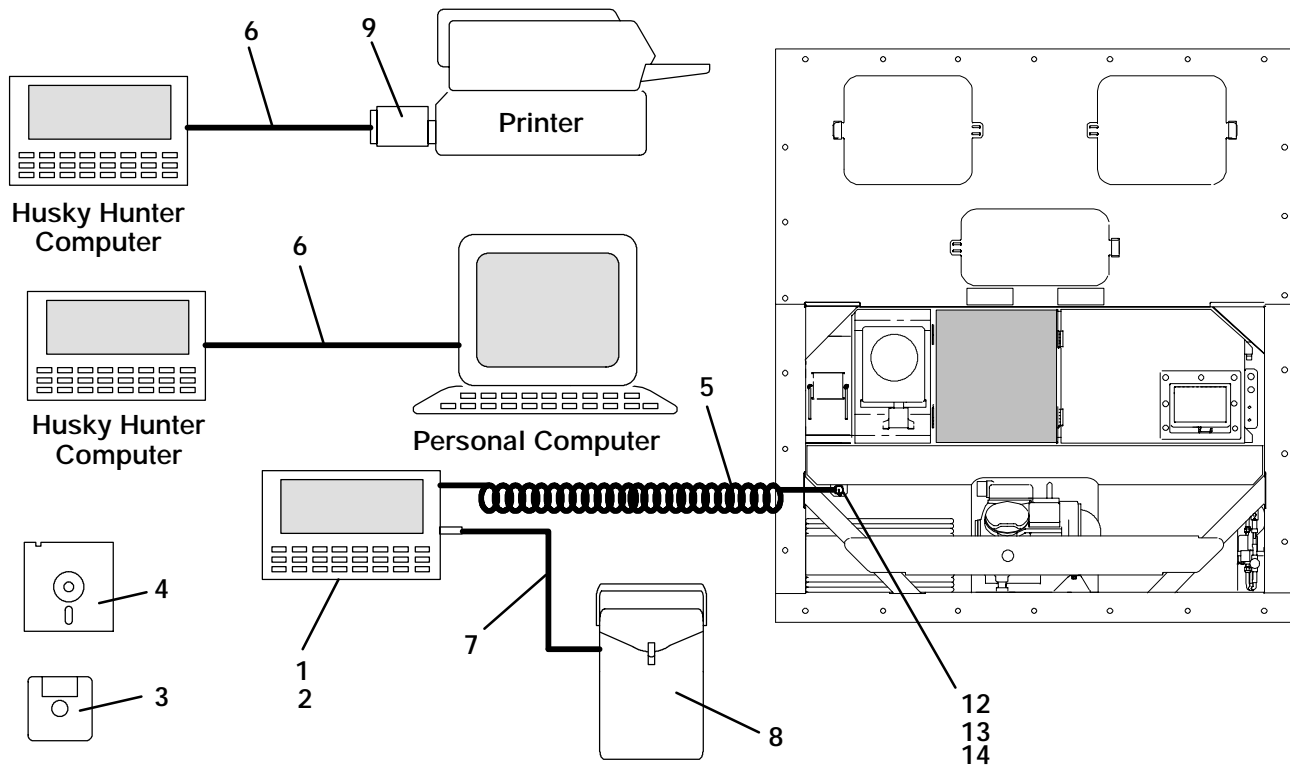

HUSKY HUNTER COMPUTER CONNECTIONS

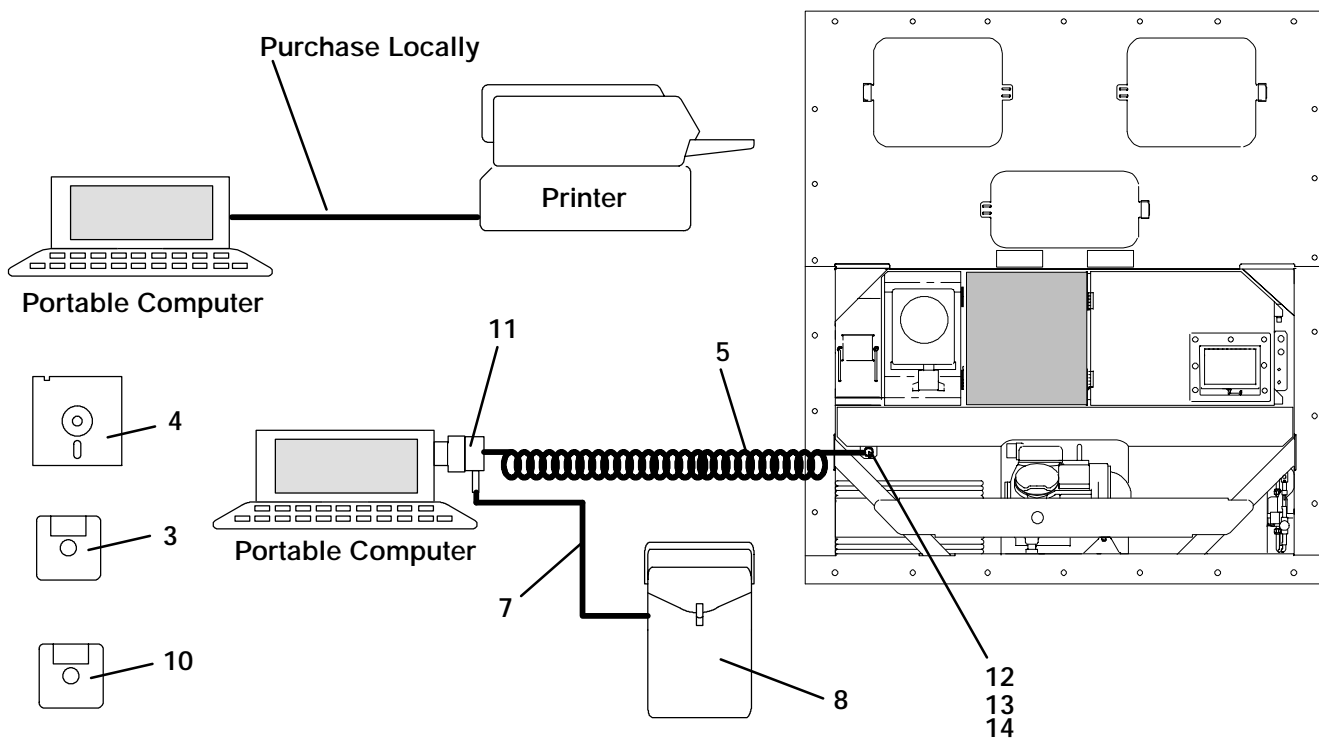

PORTABLE COMPUTER CONNECTIONS



ITEM	PART NO.	DESCRIPTION	QTY
<b>4.1 INTERROGATOR AND ACCESSORIES</b>			
1	12-01106-02	Husky Computer – 352K Memory (NSI)	1
2	58-01246-00	Case (for Husky Computer) (NSI)	1
3	12-00277-00	Software, PC and Husky Menu Program ( <b>3.5 Diskette</b> )	1
4	12-00277-01	Software, PC and Husky Menu Program ( <b>5.25 Diskette</b> )	1
5	22-02418-00	Cable, Unit to Husky or Portable Computer	1
6	22-02386-00	Cable, Husky to IBM – PC or Printer	1
7	22-02401-00	Cable, Battery Pack to Husky or Portable Computer	1
8	12-01107-00	Battery Pack with Charger	1
9	12-00279-00	Microbuffer, Mini (for Husky to Parallel Printer) (NSI)	1
10	12-01126-03	Software, Diskette for Portable Computer DataREADER Program	1
11	22-02420-00	Adapter, 25 Pin (Male) to 9 Pin (Female)	1
NS	69NT40-957	Sensor Assembly, USDA Cold Treatment – Includes:	1
NS	22-02397-04	Pin	4
12	22-02413-00	Cap & Chain	1
13	69NT40-537-3	Connector, Interrogator (Optional) (NSI) – Includes:	1
NS	22-02412-00	Receptacle	1
NS	22-02398-02	Pin, Contact	5
NS	58-01256-00	Plug	1
NS	22-02362-01	Contact	1
NS	22-02361-01	Contact	3
14	69NT40-222	Bracket, Interrogator Connector (Optional)	1

ITEM	PART NO.	DESCRIPTION	QTY
------	----------	-------------	-----

4.2 BATTERY AND CHARGER MODULE

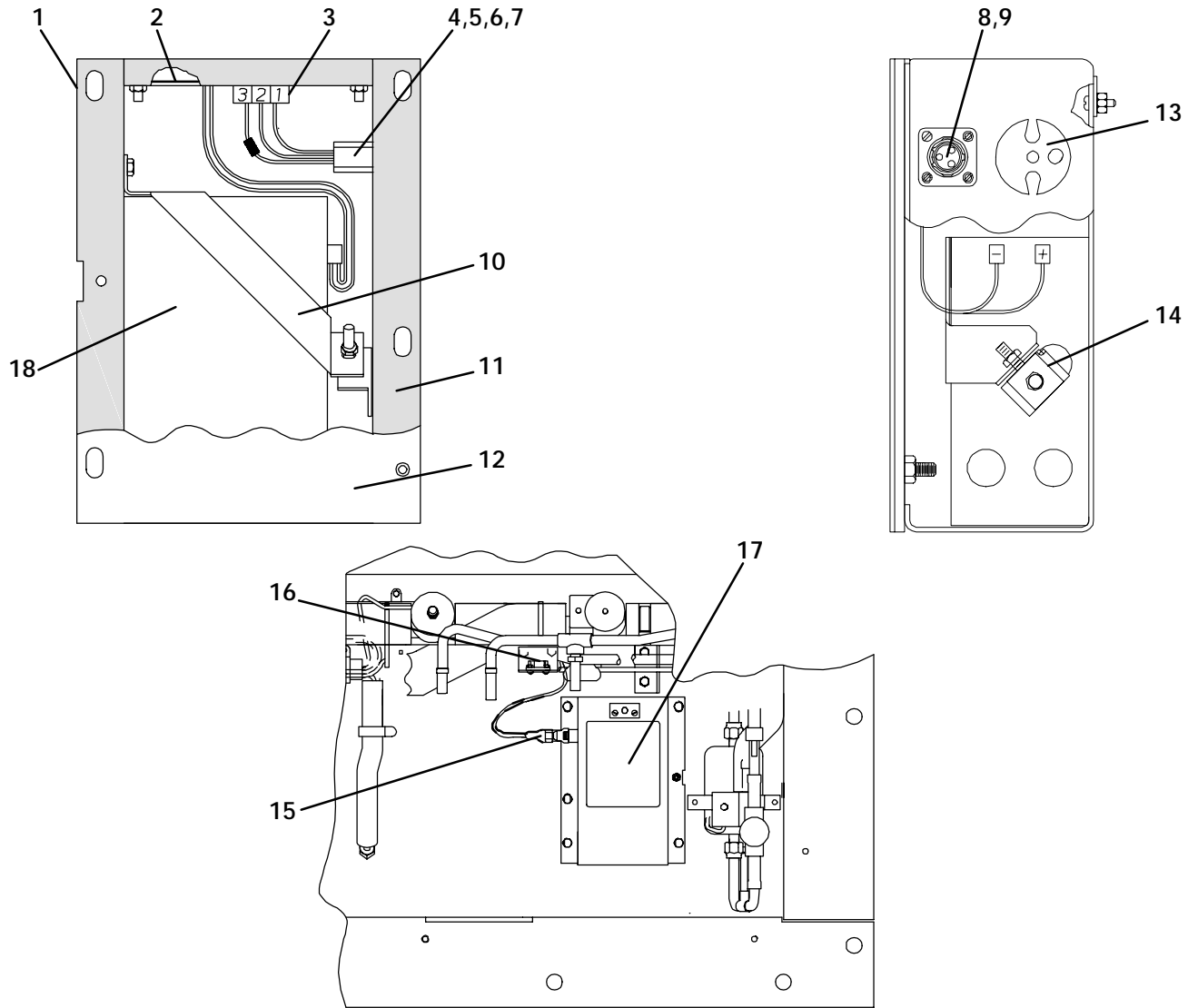

1	69NT40-177-1	Battery Box Assembly – Includes:	1
2	12-01111-00	Charger, Battery	1
3	22-01442-00	Connector, Receptacle	1
4	69NT40-682	Fuse Assembly – Includes:	1
5	22-02387-00	Holder, Fuse, In-line	1
6	HY10FJ203	Fuse, 3 Amps	1
7	22-02361-01	Contact (Pin Type)	2
8	22-02382-00	Receptacle	1
9	42-01114-00	Gasket, Receptacle (NSI)	1
10	69NT40-147	Bracket, Battery	1
11	42-01112-00	Gasket, Battery Box (NSI)	1
12	69NT40-287	Cover (NSI)	1
13	58-00660	Drain, Washer Condensate (Plastic)	2
14	42-01113-00	Gasket, Battery Bracket (NSI)	1
15	22-02383-00	Plug (for Power Cable and Dummy Plug)	2
16	22-02362-01	Socket, Terminal (for Power Cable)	3
17	69NT35-7684	Label, Charger Battery Box (NSI) (USDA)	1
* 18	10-01162-00	Battery, 12 Volt (NSI)	1
NS	69NT35-8074	Label, Charger Battery Box (NSI) <b>69NT40-444-3, -7, -8</b>	1

\* Contact your RCG Customer Representative.

ITEM	PART NO.	DESCRIPTION	QTY
------	----------	-------------	-----

4.3 USDA "C" SIZE BATTERY BOX

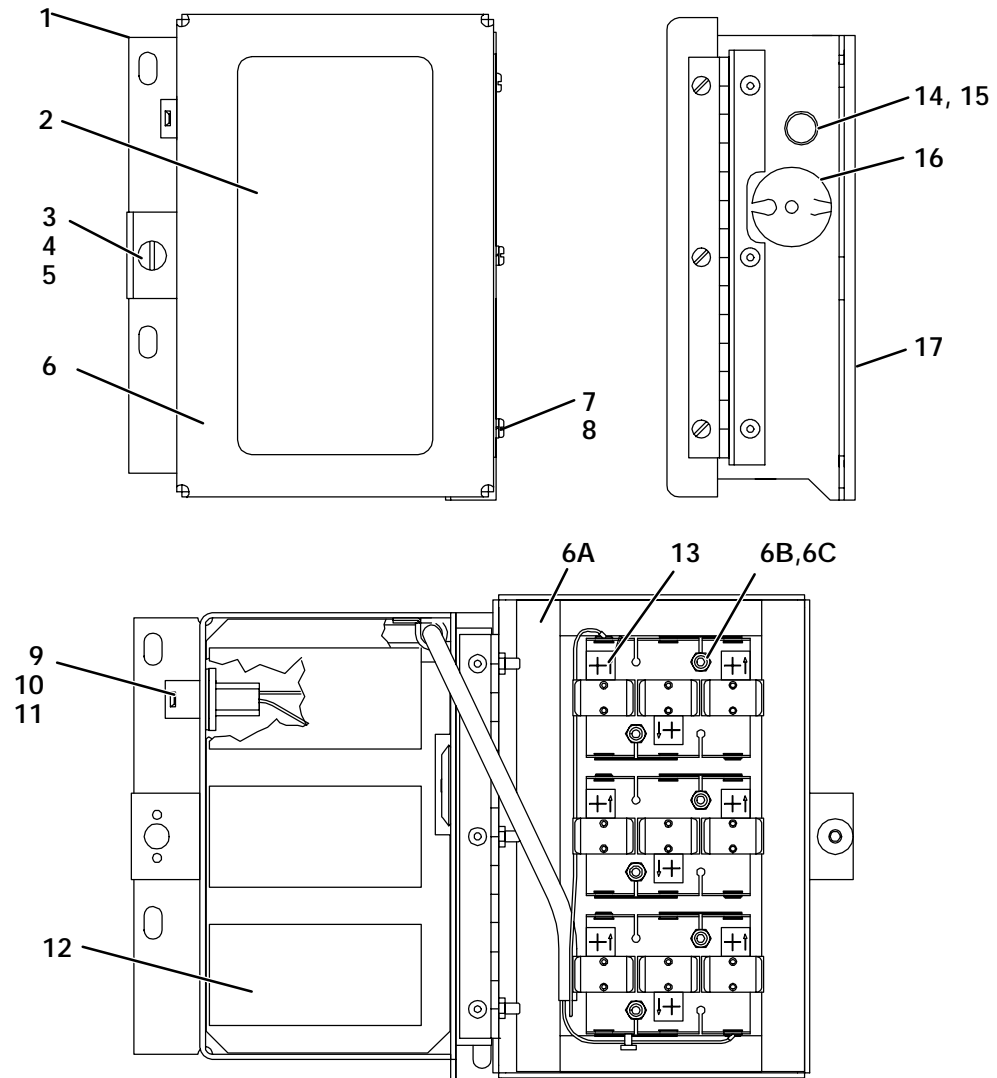

1	69NT40-997	Battery Box Assembly (NSI) – Includes:	1
2	69NT35-9563	Label, Instruction (NSI)	1
3	66U1-6811-10	Retaining, Screw	1
4	34-01226-00	Washer, Retaining	1
5	34-01142-01	Receptacle, Retaining	1
6	69NT41-143	Door (NSI) – Includes:	1
6A	42-00206-00	Gasket (NSI)	1
6B	22-01567-00	Holder, Battery	3
6C	PL	Locknut, #6-32	6
7	69NT35-6552	Bracket (NSI)	1
8	44-00303-00	Hinge (NSI)	1
9	22-02382-00	Receptacle	1
10	42-01114-00	Gasket (NSI)	1
11	22-02361-01	Contact (Pin Type)	1
12	42-00211-00	Gasket (NSI)	3
13	69NT35-6572	Label (NSI)	9
14	22-01572-00	Holder, Fuse	1
15	22-00060-22	Fuse, 1 Amp	1
16	58-00660	Drain, Washer Condensate (Plastic)	2
17	42-00207-00	Gasket, Battery Box to Unit (NSI)	1
NS	PL	Battery "C" Size (NSI)	9

5. COMPRESSOR -- MOTOR ASSEMBLY

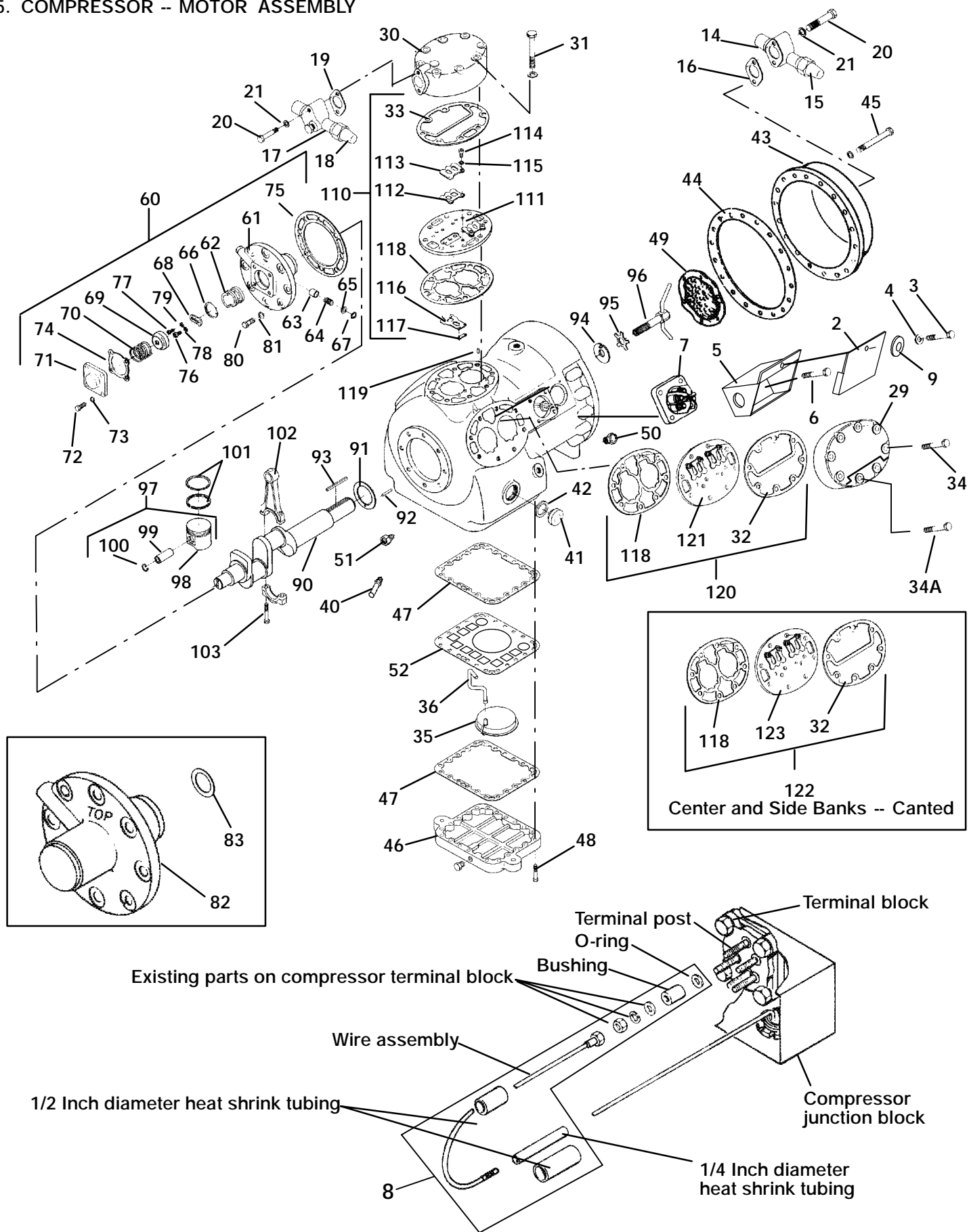

ITEM	PART NO.	DESCRIPTION	QTY
<b>5. COMPRESSOR -- MOTOR ASSEMBLY</b>			
<b>5.1 SERVICE REPLACEMENT COMPRESSOR</b>			
1	18-00043-08SV	Compressor, 28 CFM, <b>460</b> vac/3 ph/60 hz <b>69NT20-274, -1, -2, -3</b>	1
1	18-00043-06SV	Compressor, 37 CFM, <b>460</b> vac/3 ph/60 hz <b>69NT40-454, -1, -2, -3 &amp; 69NT40-444, -2, -3, -7, -8, -9, -11, -12, -13, -14, -15, -16, -17</b>	1
1	18-00043-07SV	Compressor, 37 CFM, <b>230/460</b> vac/3 ph/60 hz <b>69NT40-444-1, -4, -6, -10, -20, -21</b>	1
1	18-00043-19	Compressor, 41 CFM, <b>460</b> vac/3 ph/60 hz <b>69NT40-444-18, -19</b>	1
1	18-00043-20	Compressor, 41 CFM, <b>230/460</b> vac/3 ph/60 hz <b>69NT40-444-22, -23</b>	1
1	18-00048-21SV	Compressor, 41 CFM, <b>230/460</b> vac/3 ph/60 hz <b>69NT40-441-21, -22, -23</b>	1
1	18-00048-20SV	Compressor, 41 CFM, <b>460</b> vac/3 ph/60 hz <b>69NT40-441-24</b>	1
1	18-00048-25SV	Compressor, 37 CFM, <b>230/460</b> vac/3 ph/60 hz <b>69NT40-441-25</b>	1
<b>NOTE</b>			
The Service Replacement Motor – Compressor is sold without terminal box and cover, and without shut-off valves (but with valve pads). Customer should retain the original terminal box and valves for use on replacement compressor.			
<b>5.2 TERMINAL MOUNTING AND JUNCTION BOX GROUP</b>			
2	69NT20-2083	Cover, Junction Box	1
3	PL	Screw, Hex Head, #10-24 x 1/2 lg (cover to box)	2
4	PL	Washer, Lock, #10 (cover to box)	2
5	69NT20-513-SV	Box, Junction ( <b>Located on Front of Compressor</b> ) – Includes:	1
5	69NT20-513-1SV	Box, Junction ( <b>Located on Back of 230/460v Compressor</b> ) – Includes:	1
2	69NT20-2083	Cover, Junction Box	1
6	PL	Screw, Pan Head, #10-32 x 3/8 lg (box to compressor)	2
7	17-40093-02	Terminal, Compressor ( <b>5 Terminals</b> )	1
7	17-40093-01	Terminal, Compressor ( <b>6 Terminals</b> )	1
8	76-00355	Kit, Compressor Terminal Wiring	1
NS	76-00384	Kit, Compressor Terminal Wiring (Dual Voltage or Dual/Single Voltage)	1
NS	17-40075-05	Gasket, Terminal Plate	1
9	34-06053-05	Washer, Mylar	A/R
<b>5.3 SERVICE VALVE GROUP</b>			
14	14-01042-03	Valve, Suction Shut-Off, 1-1/8 ODS – Includes:	1
15	17-10812	Cap, Seal	1
NS	17-10806-02	Gasket, Seal Cap	1
16	17-10811-05	Gasket, Suction Service Valve	1
17	14-01042-04	Valve, Discharge Shut-Off, 7/8 ODS – Includes:	1
18	17-10812	Cap, Seal	1
NS	17-10806-02	Gasket, Seal Cap	1
19	17-10811-05	Gasket, Discharge Service Valve	1
20	66U1-5361-46	Bolt, Hex Head, 5/16-18 x 1-7/8 lg – SST (NSI)	2
21	17-40013	Gasket, Bolt, 5/16	2
<b>5.4 COMPRESSOR -- MOTOR BODY GROUP</b>			
NS	–	Gasket Set (Refer to Section 5.8)	
29	17-21040	Head, Cylinder – Side Bank (Shaved Head)	2
30	17-40016-01	Head, Cylinder – Center Bank	1
31	17-40018-05	Screw, Hex Head – Center Head, 3/8-16 x 3.00 lg – SAE Grade 5	8
32	17-55001	Gasket, Cylinder Head – Side Bank (Standard)	2
33	17-55006	Gasket, Center Cylinder Head	1
34	17-40034-05	Screw, Hex Head, 3/8-16 x 2.00 lg – SAE Grade 5	12
34A	17-40037-05	Screw, Hex Head, 3/8-16 x 1.00 lg – SAE Grade 5	4
35	17-40020-01	Screen Assembly, Oil Filter	1
36	17-40021	Tube, Oil Suction	1
40	17-44011	Valve, Oil Relief	1
41	17-10218	Sight Glass Package, Oil Level – Includes:	1
42	17-10218-02	Gasket, Sight Glass	1
43	17-20004	Cover, Motor End (NSI)	1
44	17-40029-05	Gasket, Motor End Cover	1

ITEM	PART NO.	DESCRIPTION	QTY
<b>5.4 COMPRESSOR -- MOTOR BODY GROUP (CONTINUED)</b>			
45	PL	Screw, Hex Head, 7/16-14 x 1-1/4 lg – SAE Grade 5	18
46	17-40032	Plate, Bottom	1
47	17-40033-05	Gasket, Bottom Plate	2
48	17-40034-05	Screw, Hex Head, 3/8-16 x 2.00 lg – SAE Grade 5	22
49	17-20005	Strainer Assembly, Suction (NSI)	1
50	PL	Plug, Pipe, Oil Fill, 1/4	1
51	17-40042	Check Valve Assembly, Oil Return	1
52	17-21063-00	Plate, Screen Hold Down	1
NS	PL	Pipe Plug (High & Low Pressure Connection and Oil Drain), 1/4-18 NPT	1
<b>5.5 PUMP END GROUP</b>			
60	17-40060	Bearing Head & Oil Pump Package ( <b>VANE</b> ) Consists of: (Used in 18-00043-06SV, -07SV, -08SV, -19, -20 Compressor)	1
61	NSS	Bearing Head and Oil Pump Assembly – Includes:	1
62	NSS	Pump, Rotor	1
63	NSS	Pump, Vane	2
64	17-40064	Plunger, Vane Spring	2
65	17-40065	Plunger, Vane Spring Guide	2
66	17-40068	Retaining Ring, Rotor	1
67	17-40066	Retaining Ring, Plunger	2
68	17-40071	Drive Segment, Oil Pump	1
69	NSS	Guide Vane, Oil Feed	1
70	17-40069	Vane Spring, Oil Feed	1
71	17-40076	Plate, Cover	1
72	17-40077	Screw, Hex Head, 5/16-18 x 3/4 lg – SAE Grade 5	4
73	17-40013	Gasket, Screw, 5/16	4
74	17-40075-05	Gasket, Cover Plate	1
75	17-40078-05	Gasket, Bearing Head	1
76	17-40074-01	Screw, Socket Head, 1/4-28 x 5/8 lg (Special)	1
77	17-40072	Screw, Socket Head, #10-32 x 1/2 lg (Special)	1
78	17-10715	Washer, Lock – Drive Segment, 1/4	1
79	17-40073	Washer, Lock – Drive Segment, #10	1
80	17-40037	Screw, Hex Head, Bearing Head, 3/8-16 x 1 lg – SAE Grade 5	8
81	17-40019	Gasket, Capscrew, 3/8	8
82	17-21070-00	Bearing Head & Oil Pump Package ( <b>GEAR</b> ) (Used in 18-00048-20SV -21SV, -25SV Compressor)	1
83	17-55009-01	Washer, Thrust (Used in 18-00048-20SV, -21SV, -25SV Compressor)	1
<b>5.6 CRANKSHAFT, ROD AND PISTON GROUP</b>			
90	17-21068-00	Crankshaft (Used in 18-00048-25SV Compressor)	1
90	17-21036	Crankshaft (Used in 18-00043-08SV Compressor)	1
90	17-40049	Crankshaft (Used in 18-00043-06SV, -07SV Compressor)	1
90	17-21066-00	Crankshaft (Used in 18-00043-19, -20 Compressor)	1
90	N/A	Crankshaft (Used in 18-00048-20SV, -21SV Compressor)	1
91	17-40059	Washer, Thrust	1
92	17-40048	Pin, Spiral, 5/32 Diameter x 5/8 lg	2
93	34-01110	Key, Rotor Drive	1
94	17-10831	Washer, Rotor (NSI)	1
95	17-40046	Washer, Star, Rotor, 5/8 (NSI)	1
96	17-40044	Tube Assembly, Equalizer (NSI)	1
97	17-21065-01	Piston & Pin Pkg (For 18-00043-08SV Compressor) (Standard) – Includes:	6
97	17-21065-03	Piston & Pin Pkg (For 18-00043-08SV Compressor) (+0.020) – Includes:	A/R
97	17-21064-01	Piston & Pin Pkg (For 18-00043-06SV, -07SV Compressor) (Standard) – Includes:	6
97	17-21064-03	Piston & Pin Pkg (For 18-00043-06SV, -07SV Compressor) (+0.020) – Includes:	A/R

ITEM	PART NO.	DESCRIPTION	QTY
<b>5.6 CRANKSHAFT, ROD AND PISTON GROUP (CONTINUED)</b>			
97	17-44115-01	Piston & Pin Pkg (For 18-00043-19, -20 & 18-00048-20SV, -21SV Compressor) (Standard) – Includes:	6
97	17-44115-20	Piston & Pin Pkg (For 18-00043-19, -20 & 18-00048-20SV, -21SV Compressor) (+0.020) – Includes:	A/R
97	17-44045-01	Piston & Pin (Standard) (For 18-00048-25SV Compressor) – Includes:	6
97	17-44045-03	Piston & Pin (+0.020) (For 18-00048-25SV Compressor) (NSI) – Includes:	A/R
98	NSS	Piston	1
99	17-40052-00	Pin, Piston	1
100	17-40053	Retainer, Piston Pin	2
101	17-40055	Ring, Compression (For Standard & +0.020 inch Piston)	12
102	17-40056	Connecting Rod and Cap Assembly (Standard) – Includes:	6
102	17-55023	Connecting Rod and Cap Assembly (+0.010) – Includes:	A/R
NS	17-40057	Pin, Dowel	2
103	17-55008	Capscrew – Special (Epoxy Coated)	2
<b>5.7 VALVE PLATE GROUP</b>			
110	17-55007	Package, Valve Plate Assembly (Center Bank) (For 18-00043-06SV, -07SV, -08SV, 18-00048-25SV Compressor) – Includes:	2
NS	NSS	Plate Assembly, Valve – Includes:	1
111	NSS	Plate, Valve	1
112	17-40086	Valve, Discharge	2
113	17-40087	Valve, Stop Discharge	2
114	17-44113-00	Screw, Hex Head, 1/4-28 x 3/8 lg	4
115	17-10715	Washer, Lock, 1/4	4
116	17-40082	Valve, Suction	2
117	17-40083	Spring, Suction Valve Positioning	2
33	17-55001	Gasket, Cylinder Head	1
118	17-55002	Gasket, Valve Plate	1
120	17-55003	Package, Valve Plate Assembly (Side Bank) (For 18-00043-06SV, -07SV, -08SV, 18-00048-25SV Compressor) – Includes:	2
NS	NSS	Plate Assembly, Valve – Includes:	1
121	NSS	Plate, Valve	1
112	17-40086	Valve, Discharge	2
113	17-40087	Valve, Stop Discharge	2
114	17-44113-00	Screw, Hex Head, 1/4-28 x 3/8 lg	4
115	17-10715	Washer, Lock, 1/4	4
116	17-40082	Valve, Suction	2
117	17-40083	Spring, Suction Valve Positioning	2
32	17-55001	Gasket, Cylinder Head	1
118	17-55002	Gasket, Valve Plate	1
122	17-44112-01	Package, Valve Plate Assembly (Center and Side Banks -- Canted) (For 18-00043-19, -20 & 18-00048-20SV, -21SV Compressor) – Includes:	3
NS	NSS	Plate Assembly, Valve – Includes:	1
123	NSS	Plate, Valve	1
112	17-40086	Valve, Discharge	2
113	17-40087	Valve, Stop Discharge	2
114	17-44113-00	Screw, Hex Head, 1/4-28 x 3/8 lg	4
115	17-10715	Washer, Lock, 1/4	4
116	17-44111-00	Valve, Suction	2
117	17-40083	Spring, Suction Valve Positioning	2
32	17-55001	Gasket, Cylinder Head	1
118	17-55002	Gasket, Valve Plate	1
119	17-40057	Pin, Dowel (Valve Plate)	12

ITEM	PART NO.	DESCRIPTION	QTY
------	----------	-------------	-----

5.8 GASKET SET

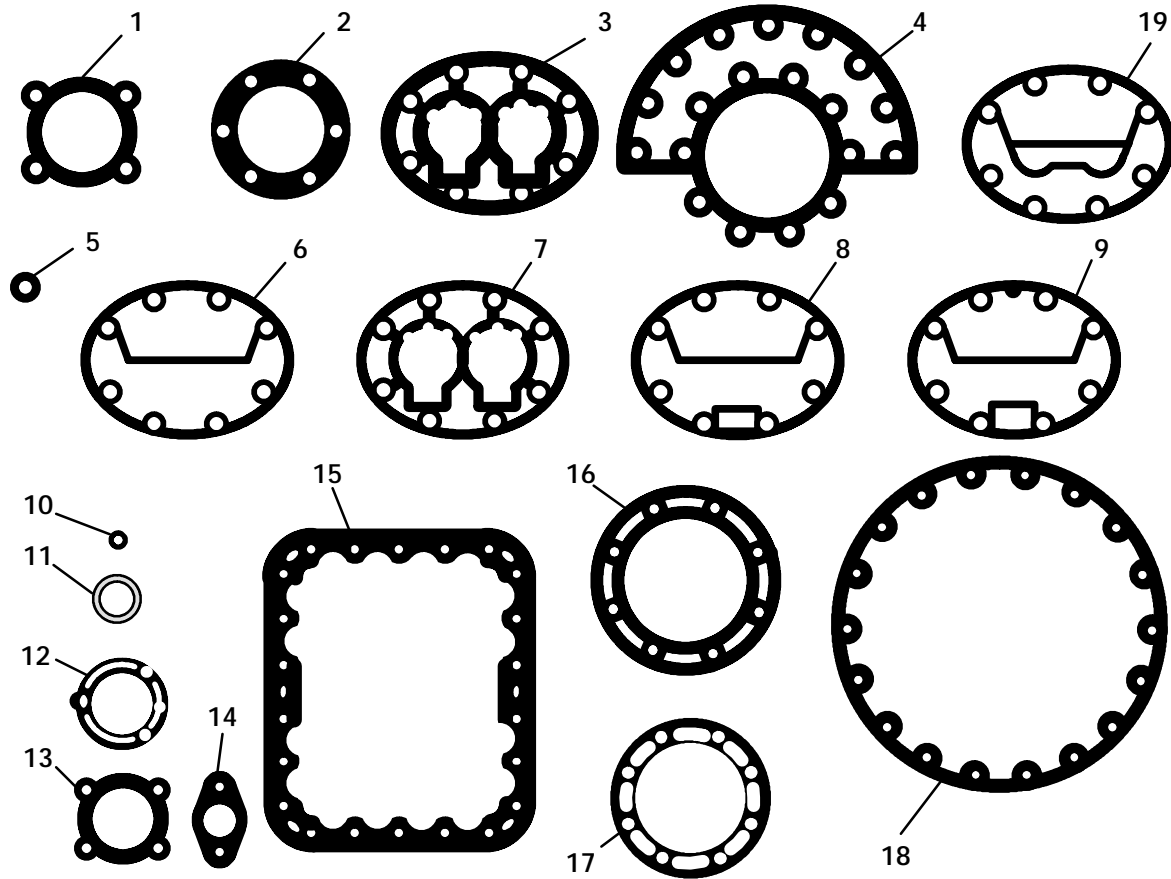

–	17-55020-20	Gasket Set – Includes:	1
1	17-40005-05	Gasket, Suction Service Valve (4 Bolt)	1
2	17-44004-05	Gasket, Shaft Seal (05G)	1
3	17-44007-05	Gasket, Valve Plate (05G)	3
4	17-44001-06	Gasket, End Flange (05G) – Includes:	1
5	17-44014	Gasket, Flange Spacer (05G)	2
6	17-55001	Gasket, Cylinder Head – Right and Left (Standard)	2
7	17-55002	Gasket, Valve Plate	3
8	17-55006	Gasket, Cylinder Head – Center	1
9	17-55005	Gasket, Cylinder Head – Right and Left (Hot Gas Bypass Unloader)	2
10	17-40316	Gasket, Oil Supply Tube (O-Ring, 05D)	1
11	17-10218-02	Gasket, Sight Glass	2
12	17-40104-07	Gasket, Unloader Body	2
13	17-40075-05	Gasket, Oil Pump Cover	1
14	17-10811-05	Gasket, Service Valve (2 Bolt)	2
15	*17-40033-05	Gasket, Bottom Plate	1
16	17-40078-05	Gasket, Pump End Bearing Head	1
17	17-40319-05	Shaft Seal (05D)	1
18	17-40029-05	Gasket, Motor End Cover	1
19	17-21042-00	Gasket, Cylinder Head (Suction Cutoff Unloader)	2

\* NOTE: When ordering for a Container Unit the quantity is two (2).



## 6. CONTROLLER AND RECORDER SENSORS

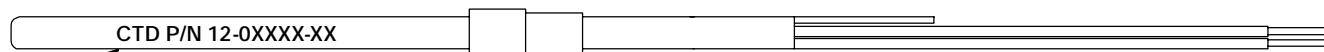

NOTE: Verify the part number that is stamped on the sensors probe when repairing and make sure to replace with the same part number.

NOTE: P/N 12-01090-00 and P/N 12-00306-00 (2 lead probe – RTD) are the same sensors, except the cable for P/N 12-00306-00 is longer.

P/N 12-01119-00 (4 lead probe – RTD) – Platinum.

P/N 12-00278-01 (2 lead probe – Thermistor)

Model Number	STS P/N	SRS P/N	RTS P/N	RRS P/N
69NT20-274	12-00306-00	12-00306-00	12-00306-00	12-01119-00
69NT20-274-1	12-00278-01	NONE	12-00278-01	NONE
69NT20-274-2	12-00306-00	12-00306-00	12-00306-00	12-01119-00
69NT20-274-3	12-00306-00	12-00306-00	12-00306-00	12-01119-00
69NT40-441-21	12-00306-00	12-00306-00	12-00306-00	12-01119-00
69NT40-441-22	12-00306-00	12-00306-00	12-00306-00	12-01119-00
69NT40-441-23	12-00306-00	12-00306-00	12-00306-00	12-01119-00
69NT40-441-24	12-00306-00	12-00306-00	12-00306-00	12-01119-00
69NT40-441-25	12-00306-00	12-00306-00	12-00306-00	12-01119-00
69NT40-444	12-01090-00	12-01090-00	12-01090-00	12-01119-00
69NT40-444-1	12-01090-00	12-01090-00	12-01090-00	12-01119-00
69NT40-444-2	12-01090-00	12-01090-00	12-01090-00	12-01119-00
69NT40-444-3	12-01090-00	12-01090-00	12-01090-00	12-01119-00
69NT40-444-4	12-01090-00	NONE	12-01090-00	NONE
69NT40-444-6	12-00306-00	NONE	12-00306-00	NONE
69NT40-444-7	12-00306-00	12-00306-00	12-00306-00	12-01119-00
69NT40-444-8	12-00306-00	12-00306-00	12-00306-00	12-01119-00
69NT40-444-9	12-01090-00	12-01090-00	12-01090-00	12-01119-00
69NT40-444-10	12-00306-00	12-00306-00	12-00306-00	12-01119-00
69NT40-444-11	12-01090-00	12-01090-00	12-01090-00	12-01119-00
69NT40-444-12	12-00306-00	12-00306-00	12-00306-00	12-01119-00
69NT40-444-13	12-00306-00	12-00306-00	12-00306-00	12-01119-00
69NT40-444-14	12-00306-00	12-00306-00	12-00306-00	12-01119-00
69NT40-444-15	12-00306-00	12-00306-00	12-00306-00	12-01119-00
69NT40-444-16	12-00306-00	12-00306-00	12-00306-00	12-01119-00
69NT40-444-17	12-00278-01	12-00278-01	12-00278-01	12-01119-00
69NT40-444-18	12-00306-00	12-00306-00	12-00306-00	12-01119-00
69NT40-444-19	12-00306-00	12-00306-00	12-00306-00	12-01119-00
69NT40-444-20	12-00306-00	12-00306-00	12-00306-00	12-01119-00
69NT40-444-21	12-00306-00	12-00306-00	12-00306-00	12-01119-00
69NT40-444-22	12-00306-00	12-00306-00	12-00306-00	12-01119-00
69NT40-444-23	12-00306-00	12-00306-00	12-00306-00	12-01119-00
69NT40-454	12-01090-00	12-01090-00	12-01090-00	12-01119-00
69NT40-454-1	12-00278-01	12-00278-01	12-00278-01	12-01119-00
69NT40-454-2	12-00306-00	12-00306-00	12-00306-00	12-01119-00
69NT40-454-3	12-00306-00	12-00306-00	12-00306-00	12-01119-00

STS – SUPPLY TEMPERATURE SENSOR  
 SRS – SUPPLY RECORDER SENSOR  
 RTS – RETURN TEMPERATURE SENSOR  
 RRS – RETURN RECORDER SENSOR